

SINGER

400W108

Form 2979w

(148)

Printed in U. S. A.

**LIST
OF
PARTS**



SINGER**

MACHINE No. 400w108

THE SINGER MANUFACTURING COMPANY

****A Trade Mark of THE SINGER MANUFACTURING COMPANY**

From the library of: Diamond Needle Corp

INSTRUCTIONS FOR OILING

To ensure easy running and prevent unnecessary wear of the parts which are in movable contact, the machine requires oiling, and when in continuous use, "TYPE A" or "TYPE C" OIL, sold by Singer Sewing Machine Company, should be applied at least twice each day to all oil holes marked "OIL", as instructed in Form 2967w.

Copyright, U. S. A., 1939, 1940, 1941, 1942,
1946 and 1948
by The Singer Manufacturing Company
All Rights Reserved for all Countries

INDEX

	PAGE
ACCESSORIES	12
BELT GUARD	18
BINDERS	14
BOBBIN HOLDER	17
BOBBIN WINDERS	13 & 17
CORDER	18
FINGER GUARD	19
FITTINGS	28
GUIDE	19
HEMMERS	19
KNEE LIFTER	12
MACHINE NO. 400w108	5
MISCELLANEOUS PARTS	24
NUMERICAL LIST OF PARTS	35
PIPING ATTACHMENT	21
PRESSER FEET	21
PULLER FEED	25
THREAD UNWINDER	26
TUCKER	26
WOOD BASE	28

From the library of: Diamond Needle Corp

INSTRUCTIONS FOR ORDERING

In ordering from this list, use **ONLY** the **PART** number in the **FIRST** column.

The number stamped on a Sewing Machine Part is the number of the **Single Part** only, except when the part includes Set Screws, Clamping Screws, Studs and Rollers Spun on, Small Wires riveted, or Parts soldered together, etc., which it is necessary to furnish in combination.

Every combination of parts sent out has its specific number which, although not stamped on Parts (except in above case), must be used when ordering the combination.

Each number always indicates the **SAME PART** in whatever list it appears, or for whatever Machine.

The letters after some of the numbers indicate the style of finish only, as follows:

- A. Hardened, Polished, Nickel Plated and Buffed.
- B. Polished, Nickel Plated and Buffed.
- C. Hardened only.
- D. Polished only.
- E. Soft, not polished.
- F. Hardened and Polished.
- H. Blued.
- J. Nickel Plated only.
- R. Merlized.
- X. Black Oxide, for Iron and Steel.
- XC. Hardened and Black Oxide, for Iron or Steel.
- Y. Black Nickel Plated only.

These letters **MUST BE USED** when they appear in the list and **AFTER** the number, as in the list.

In this series

1 to 1500, 200001 to 201500 and 350001 to 351500 are Screw Numbers.
 1501 to 1800, 201501 to 201800 and 351501 to 351800 are Nut Numbers.
 1801 to 2000, 201801 to 202000 and 351801 to 352000 are Roller Numbers.
 2001 to 50000 and 202001 to 350000 are Numbers of Machine Parts.

The figures in the second column refer only to the plate in which the illustration of the part is shown and are **NOT TO BE USED** in ordering.

Two or more numbers over a cut indicate that the difference between such parts is not visible in an illustration.

Parts marked with an asterisk (*) are furnished only when repairs are made at the factory.

LIST OF PARTS COMPLETE

FOR

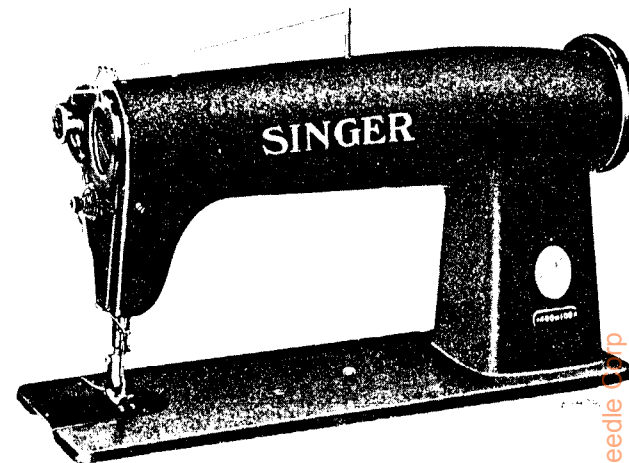

MACHINE No. 400w108

HIGH SPEED. LONG ARM.

DOUBLE ROTARY DISC TAKE-UP

SINGLE NEEDLE. LOCK STITCH. DROP FEED.

MAXIMUM STITCH 5 1/2 TO THE INCH.

NEEDLE BAR STROKE 1 9/64 INCHES. PRESSER BAR LIFT 5/16 INCH

FOR STITCHING MEDIUM AND MEDIUM HEAVY FABRICS.

No.	Plate	Name
*270251	-----	Arm
270002	18332	" Cover Plate (back)
200041X	18332	" " " Screw (2)
204235	18332	" Position Pin (2)
200004E	18332	" Screw (3)
202005	18332	" " Washer (3)
*270252	18391	" Shaft
270325	18391	" " 270252 with 200333C, 200362C, 270005 and 270320
270004	18391	Arm Shaft Ball Bearing (back)
270005	18391	" " " " (front)
270926	18391	" " Connection Belt (reinforced neoprene)
270168	18391	Arm Shaft Connection Belt Pulley and Rotary Take-up Driving Pulley with 200363AL, 350492C and three 214206

From the library of: Diamond Needle Corp

No.	Plate	Name
200374C	18391	Needle Bar Connecting Link Hinge Stud Set Screw
270266	18393	Needle Bar Connecting Link Needle Bearing
270305	18393	Needle Bar Connecting Link Thrust Washer
270856	18393	Needle Bar Connecting Stud with 200086C and 202330
202330	18393	Needle Bar Connecting Stud Oil Packing (wick)
200086C	18393	Needle Bar Connecting Stud Pinch Screw
*270320	18391	" " Crank with two 200374C
200333C	18391	" " " Position Screw
200362C	18391	" " " " Screw Check Screw
270058	18393	Needle Bar Oiling Felt
350445F	18393	" Set Screw
270269	18393	Presser Bar with 176J
270114	18393	" " Bushing
270061	18393	" " Lifter
350442C	18393	" " " Hinge Screw
270062	18393	" " Lifting Releasing Lever Bracket
270095	18393	Presser Bar Lifting Releasing Lever Bracket Spring
270063	18393	Presser Bar Position Guide with 200196E and 350411C
350411C	18393	Presser Bar Position Guide Pinch Screw
270271	18332	" " Spring
350435C	18332	" " " Screw (pressure regulating)
350499XC	18332	Presser Bar Spring Screw Stud
26276	18392	" Foot Hinge Pin
19334	18392	" " Plate
143364	18392	" " Shank
26231	18392	" " Spring
143365	18393	Presser Foot (spring hinged) complete, Nos. 19334, 26231, 26276 and 143364
176J	18393	Presser Foot Screw
270916	18394	Rotary Take-up (large)
270161	18393	" " " Position Pin
401D	18394	" " " Screw (2)
271032	18394	" " " Thread Guide
270906	18384	" " (small) with 270147 and 350418C
270273	18384	Rotary Take-up (small) Driving Shaft
270032	18384	" " " " "
270069	18384	Ball Bearing (2)
270072	18384	Rotary Take-up (small) Driving Shaft Connection Belt
200382C	18384	Rotary Take-up (small) Driving Shaft Pulley with two 200382C
350418C	18384	Rotary Take-up (small) Driving Shaft Pulley Set Screw
270147	18384	Rotary Take-up (small) Set Screw
		" " " Thread Cast-off Pin

No.	Plate	Name
270148	18394	Rotary Take-up Guard
350503H	18394	" " " Screw (3)
270868	18379	Rotating Hook with 143301 and two 1253AL
270869	18379	Rotating Hook 270868 with 270874 and four 1053E
270870	18379	Rotating Hook 270869 with 270872, 270876 and three 1367E
270871	18379	Rotating Hook 270870 with 52237
270010	18379	" " Bobbin
52235	18379	" " " Case
52236	18379	" " " " 52235 with 591F, 1380E and 40394
40393	18379	Rotating Hook Bobbin Case Hinge, Nos. 2974, 40392 and 125320
270872	18379	Rotating Hook Bobbin Case Holder (chromium plated)
52018	18379	Rotating Hook Bobbin Case Holder Position Bracket
200077D	18379	Rotating Hook Bobbin Case Holder Position Bracket Screw
40392	18379	Rotating Hook Bobbin Case Latch
125320	18379	" " " " " Lever
2974	18379	" " " " " "
		Fulcrum Pin
2975	18379	Rotating Hook Bobbin Case Latch Spring
592E	18379	" " " " " Stop Screw
40394	18379	Rotating Hook Bobbin Case Tension Spring
591F	18379	Rotating Hook Bobbin Case Tension Spring Regulating Screw
1380E	18379	Rotating Hook Bobbin Case Tension Spring Screw
52237	18379	Rotating Hook Bobbin Case complete, Nos. 592E, 2975, 40393 and 52236
270873	18379	Rotating Hook Bobbin Case 52237 with 270872
270276	18389	Rotating Hook Driving Shaft
270032	18389	" " " " Ball Bearing
270033	18389	Rotating Hook Driving Shaft Bushing with 222598
222598	18389	Rotating Hook Driving Shaft Bushing Oil Packing (wick)
200362C	18389	Rotating Hook Driving Shaft Bushing Set Screw
270169	18389	Rotating Hook Driving Shaft Connection Belt Pulley with 214206 and two 200070C
200070C	18389	Rotating Hook Driving Shaft Connection Belt Pulley Set Screw
214206	18389	Rotating Hook Driving Shaft Connection Belt Pulley Spring Flange
270035	18389	Rotating Hook Driving Shaft Gear (internal teeth) with 200382C and 201220C

No.	Plate	Name
201220C	18389	Rotating Hook Driving Shaft Gear Position Screw
200382C	18389	Rotating Hook Driving Shaft Gear Set Screw
270036	18389	Rotating Hook Driving Shaft Oil Lead Wire
270038	18332	Rotating Hook Oil Reservoir Cover
270039	18332	" " " " Cover Gasket
200041X	18332	Rotating Hook Oil Reservoir Cover Screw (6)
270155	18389	" " " " Oil Gauge
143301	18379	" " " Wick (felt)
270876	18379	" " Section
1367E	18379	" " Screw
1253AL	18379	" " Set Screw
270162	18389	" " Shaft
270163	18389	" " Bushing
268258	18389	" " " " Oil Packing (wick)
350277C	18389	Rotating Hook Shaft Bushing Set Screw
270164	18389	" " " End Bearing
201215D	18389	" " " " Screw
202423	18389	" " " Oil Filter Wick
143349	18389	" " " " " "
		Holder
270176	18389	Rotating Hook Shaft Oil Filter com- plete, Nos. 143349 and 202423
350498E	18389	Rotating Hook Shaft Oil Regulating Screw
270044	18389	Rotating Hook Shaft Thrust Washer
270166	18389	Rotating Hook Shaft Bushing complete, Nos. 268258, 270044, 270162 to 270164, 270176, 350498E and two 201215D
270874	18379	Rotating Hook Thread Guard
1053E	18379	" " " " Screw
2102	18394	Tension Disc
270277	18393	" Releaser (adjustable)
200132E	18393	" " Screw
32572	18394	" Releasing Disc
270278	18394	" " Pin
13710	18394	" Spring
350457C	18394	" Stud
200377C	18394	" " Set Screw
1560C	18394	" Thumb Nut
270279	18394	Tension complete, Nos. 1560C, 13710, 32572, 52082, 270278, 270281, 350457C and two 2102
270096	18394	Thread Guide
236245	18394	" " (lower)
263118	18393	" " (on needle bar bushing)
350503H	18394	" " Screw (2)
270280	18393	" Pull-off
200196E	18393	" " Set Screw
270080	18394	" Retainer
200355H	18394	" " Set Screw
270150	18394	" Severing Finger
270151	18394	" " " Guard

No.	Plate	Name
350486XC	18394	Thread Severing Finger Guard Hinge Screw
270156	18394	Thread Severing Finger Guard Hinge Screw Spring Washer
200567H	18394	Thread Severing Finger Screw
52082	18394	" Take-up Spring
270281	18394	" " " Regulator with 200377C
446C	18394	Thread Take-up Spring Regulator Set Screw
270326	18392	Throat Plate (large needle hole)
691F	18392	" " Screw (2)

**SINGER Needles should be used
in SINGER Machines
These Needles and their Containers
are marked with the
Company's Trade Mark "SIMANCO."** 1**

**Needles in Containers marked
"FOR SINGER MACHINES"
are NOT SINGER made needles. 2**

ACCESSORIES

No.	Plate	Name
50190W	18332	Attachment Thumb Screw
25878	18287	Guide
270010	18379	Rotating Hook Bobbin (2)
228476	18287	Screw Driver (Bobbin Case)
135x25	----	Needles, six, size 21
228393	18333	Drip Pen with four 3/4 in. wire nails
12361	18287	Machine Hinge Connection (2)
41400	18287	" Rest Pin (wood)
120342	18287	Oiler (copper plated) with 120343
120343	18287	" Spout (3-1/2 in. long)
259477	18287	Screw Driver, 5 in. long

KNEE LIFTER

228486	18333	Rock Lever Bracket with 200347C and three wood screws 7/8 in., No. 12
228361	18333	Rock Lever Bracket 228486 with 228359, 228363, 228367, 228386 and 228455
228359	18333	Rock Lever with two 350231C
228370	18333	" " Extension with 200529C
350231C	18333	" " " Set Screw
228363	18333	" " Hinge Pin
228364	18333	" " Knee Plate with 350231C
228388	18333	" " " " Arm
350231C	18333	" " " " " Set Screw
350231C	18333	" " " " " Set Screw
228455	18333	" " Position Spring
228365	18333	" " Rod
200529C	18333	" " " Set Screw
228386	18333	" " Spring
228367	18333	" " Stop Stud
200347C	18333	" " " " Set Screw
228371	18333	Knee Lifter Rock Lever complete, Nos. 228361, 228364, 228365, 228370 and 228388

(Other Knee Lifter parts are listed with parts of machine head)

BOBBIN WINDER

(SWINGING AUTOMATIC, RIGHT HAND)

FOR "V" BELT DRIVE

No.	Plate	Name
259428	18312	Brake (leather)
259429	18312	" Clamp
200113F	18312	" " Screw
225453	18312	Frame with 202277 and 259660
225454	18312	" Hinge Pin
202277	18312	" Oil Packing (wick)
259660	18312	" " Well Washer
225455	18312	" Spring
225456	18312	" " Plunger
259461	18312	Pulley with 200380C
200380C	18312	" Set Screw
225381	18312	Spindle
225444	18312	Stop Latch
200056E	18312	" " Screw
225458	18312	" " Thumb Lever
225459	18312	" " " " Hinge Stud
202478	18312	" " " " Joint Stud
200299H	18312	" " Trip Lever
225461	18312	" " " " Hinge Screw
200082D	18312	Tension Bracket with 201499H
22C026	18312	" " " Screw
2102	18312	" " " Washer
13710	18312	" Disc
201499H	18312	" Spring
201572H	18312	" Stud
225462	18312	" " Thumb Nut
		Bobbin Winder Tension Bracket complete, Nos. 13710, 201572H, 225461 and two 2102
259662	18312	Bobbin Winder and Tension Bracket Base
259462	18312	Universal Bobbin Winder complete, Nos. 200056E, 200082D, 200113F, 200299H, 202478, 225381, 225444, 225453 to 225456, 225458, 225462, 228026, 259428, 259429, 259461, 259662, two each 225459 and wood screws 3/4 in., No. 12, R.H.B.

BINDERS

BINDER (English)

FOR GAUGES UP TO $\frac{9}{16}$ INCH

No.	Plate	Name
121444	23226	Feed Dog, 13 teeth (16 teeth to the inch)
25721	23226	Folder
207F	23226	" Screw
7071	23226	" " Washer
25983	23226	Presser Foot
25722	23226	Ribbon Tension
190D	23226	" " Screw
7071	23226	" " Washer
121445XC	23226	Throat Plate
26250	23226	Binder complete, Nos. 190D, 207F, 25721, 25722, 25983, 121444, 121445 and two 7071

BINDER (English)

FOR HEAVY WORK

No.	Plate	Name
12370	18359	Feed Dog, 15 teeth (16 teeth to the inch)
28334	18359	Folder
193D	18359	" Screw
7071	18359	" " Washer
28676	18359	Presser Foot
28337	18359	Ribbon Tension
233J	18359	" " Screw
28775XC	18359	Throat Plate
28776	18359	Binder complete, Nos. 193D, 7071, 12370, 28334, 28337, 28676, 28775 and two 233J

BINDER ON SHANK

35208	23228	Binder on Shank to turn in both edges, for bias or straight binding for skirts, wrappers, shirt waists, etc.
26603	23228	Feed Dog, 20 teeth (16 teeth to the inch), for 26605 and 26606
52055	23228	Presser Foot

No.	Plate	Name
26605XC	23228	Throat Plate (large needle hole), for 26603
26606XC	-----	Throat Plate (small needle hole), for 26603

BINDER (Bias)

(WITH TAPE REEL)

FOR GENERAL WORK

FOR $\frac{7}{8}$ IN. BIAS BINDING

259778	18373	Binder, for $\frac{7}{8}$ in. binding
259779	18373	" Bracket
350511D	18373	" " Thumb Screw
225604H	18373	" " " " Washer
200126F	18373	" Screw
202603	18373	" " Washer
259780	18373	Feed Dog
202090	18373	Presser Foot Hinge Pin
259781	18373	" " Plate
270643	18373	" " Shank
26231	18373	" " Spring
259782	18373	Presser Foot (spring hinged) complete, Nos. 26231, 202090, 259781 and 270643
121412	18373	Tape Reel Arm with 8879, 23263 and 120537
207D	18373	Tape Reel Arm Screw
23263	18373	" " " Steady Pin
120536	18373	" " Disc with 120538 and 120539
120537	18373	" " " Pin
8879	18373	" " " " Washer (cloth)
120538	18373	" " " Stud (wood)
120539	18373	" " " " Sleeve (brass)
259783	18373	Throat Plate
259784	18373	Binder complete, for $\frac{7}{8}$ in. bias binding, Nos. 207D, 120536, 121412, 200126F, 202603, 225604H, 259778 to 259780, 259782, 259783 and 350511D

**BINDER (Transverse) ON SHANK
FOR FOLDED OR UNFOLDED BIAS BINDING**

(WITH TAPE REEL)

FOR GENERAL WORK

FOR 3/4 IN., 7/8 IN. AND 1 IN. TAPE

No.	Plate	Name
121167	22919	Binder Folder on Shank
43525	22919	" Steady Pin
51097J	22919	" Thumb Screw
3146	22919	" " " Washer
121397	22919	Feed Dog, 18 teeth (16 teeth to the inch)
121169	22919	Presser Foot
121412	22919	Tape Reel Arm with 8879, 23263 and 120537
23263	22919	Tape Reel Arm Steady Pin
51097J	22919	" " " Thumb Screw
120536	22919	" " Disc with 120538 and 120539
120537	22919	" " " Pin
8879	22919	" " " Washer (cloth)
120538	22919	" " " Stud (wood)
120539	22919	" " " Sleeve (brass)
121398XC	22919	Throat Plate with 43525
121168	22919	Binder (transverse) on Shank complete, Nos. 3146, 120536, 121167, 121169, 121397, 121398, 121412 and two 51097J

**BINDER (Transverse) ON THROW-OUT ARM
FOR FOLDED OR UNFOLDED BIAS BINDING**

(WITH TAPE REEL)

FOR GENERAL WORK

FOR 3/4 IN., 7/8 IN. AND 1 IN. TAPE

No.	Plate	Name
121732	23229	Binder (transverse)
121735	23229	" Releasing Lever
724F	23229	" " " Hinge Screw
121736	23229	" " " Spring
192349	23229	" " " " Position
		Stud
1443J	23229	Binder Screw

No.	Plate	Name
121733	23229	Binder Throw-out Arm with 192349
121734	23229	" " " Bracket Rivet
940F	23229	" " " Hinge Screw
35610	23229	" Washer
121738	23229	Feed Dog, 17 teeth (16 teeth to the inch)
121169	23229	Presser Foot
120536	23229	Tape Reel Disc with 120538 and 120539
120538	23229	" " " Stud (wood)
120539	23229	" " " Sleeve (brass)
120740	23229	" " Pin
121938XC	23229	Throat Plate with two 121734
121737	23229	Binder (transverse) with Throw-out Arm complete, Nos. 724F, 940F, 35610, 120536, 120740, 121169, 121732, 121733, 121735, 121736, 121738, 121938XC and two 1443J

BOBBIN HOLDER

225434	18316	Bobbin Holder
--------	-------	---------------

BOBBIN WINDER

(SWINGING AUTOMATIC, RIGHT HAND)

FOR 5/16" ROUND BELT DRIVE

259428	18312	Brake (leather)
259429	18312	" Clamp
200113F	18312	" " Screw
225453	18312	Frame with 202277 and 259660
225454	18312	" Hinge Pin
202277	18312	" Oil Packing (wick)
259660	18312	" Well Washer
225455	18312	" Spring
225456	18312	" " Plunger
225368	18312	Pulley with 200380C
200380C	18312	" Set Screw
225381	18312	Spindle
225444	18312	Stop Latch
200056E	18312	" " Screw
225458	18312	" " Thumb Lever
225459	18312	" " " Hinge Stud
225459	18312	" " " Joint Stud
202478	18312	" " Trip Lever
200299H	18312	" " " Hinge Screw
225461	18312	Tension Bracket with 201499H
200082D	18312	" " Screw

BOBBIN WINDER

No.	Plate	Name
228026	18312	Tension Bracket Screw Washer
2102	18312	" Disc
13710	18312	" Spring
201499H	18312	" Stud
201572H	18312	" " Thumb Nut
225462	18312	Bobbin Winder Tension Bracket complete, Nos. 13710, 201572H, 225461 and two 2102
259430	18312	Bobbin Winder and Tension Bracket Base
259431	18312	Universal Bobbin Winder complete, Nos. 200056E, 200082D, 200113F, 200299H, 202478, 225368, 225381, 225444, 225453 to 225456, 225458, 225462, 228026, 259428 to 259430, two each 225459 and wood screws 3/4 in., No. 12, R.H.B.

CORDER (Adjustable)

FOR SHORT TURNS ON CUSHIONS

WHEN ORDERING STATE SIZE OR NUMBER

OF CORDS TO THE INCH

26795	23228	Cord Guide
26796	23228	" " Arm
1044D	23228	" " " Hinge Screw
120206	23228	" " " Bed with 457AL
457AL	23228	" " " Leveling Screw
190D	23228	" " " Screw
120207	23228	Corder complete, Nos. 190D, 1044D, 26795, 26796 and 120206
121446	23228	Feed Dog, spiked teeth, 13 teeth (10 teeth to the inch), for 121447
120208	23228	Presser Foot (grooved)
121447XC	23228	Throat Plate, for 121446

BELT GUARD

270153	18375	Belt Guard Bracket
350328H	18375	" " " Screw (2)
200362C	18375	" " " Set Screw (2)
270152	18375	" " " with two 200362C
270154	18375	Belt Guard complete, Nos. 270152, 270153 and two 350328H

FINGER GUARD

No.	Plate	Name
259502	18359	Finger Guard

GUIDE

26682	18360	Guide (combination)
-------	-------	---------------------

HEMMERS

HEMMERS (Foot)

225423	18316	Hemmer (foot), for 5/64 in. hem
120938	23230	" " " 3/32 in. hem
225421	18316	" " " 3/32 in. hem
225424	18316	" " " 1/8 in. hem
120803	23230	" " " 1/8 in. hem
270120	18360	" " " 1/8 in. hem
		for hemming shirts
225425	18316	Hemmer (foot), for 9/64 in. hem
120804	23230	" " " 5/32 in. hem
225422	18316	" " " 5/32 in. hem
120805	23230	" " " 3/16 in. hem
225426	18316	" " " 3/16 in. hem
36122	23230	" " " 7/32 in. hem
225427	18316	" " " 7/32 in. hem
120806	23230	" " " 1/4 in. hem
225428	18316	" " " 1/4 in. hem
120807	23230	" " " 5/16 in. hem
121761	23230	" " " with 121981, for 1/8 in. hem, for hemming shirts
121762	23230	Hemmer (foot) with 121981, for 5/32 in. hem
121760	23230	Hemmer (foot), for 1/8 in. hem, for hemming shirts
121758	23230	Feed Dog, 13 teeth (16 teeth to the inch), for 121759
270121	18360	Feed Dog, for 270122
121759XC	23230	Throat Plate (large needle hole), for 121758
270122	18360	Throat Plate (small needle hole), for 270121
35710	23230	Hemmer (foot), for 3/32 in. hem with guide on bottom to the right of needle hole

HEMMERS

No.	Plate	Name
35682	23230	Hemmer (foot), for 1/8 in. hem with guide on bottom to the right of needle hole
36524	23230	Hemmer (foot), for 5/32 in. hem with guide on bottom to the right of needle hole
35997	23230	Hemmer (foot), for 3/16 in. hem with guide on bottom to the right of needle hole
36309	23230	Hemmer (foot), for 7/32 in. hem with guide on bottom to the right of needle hole
36072	23230	Hemmer (foot), for 1/4 in. hem with guide on bottom to the right of needle hole
120898	23230	Hemmer (foot), for 1/16 in. to 1/8 in. hem, for China Silk, etc.
120911	23230	Hemmer (foot), for 5/32 in. to 1/4 in. hem, for China Silk, etc.
36413	23230	Hemmer (foot), plain bottom, for 1/16 in. hem
36414	23230	Hemmer (foot), plain bottom, for 3/32 in. hem
36480	23230	Hemmer (foot), plain bottom, for 5/32 in. hem
36416	23230	Hemmer (foot), plain bottom, for 3/16 in. hem
120837	23230	Hemmer (foot), plain bottom, for 1/8 in. hem slotted, for lace
121981	-----	Hemmer Tongue, for 121761, 121762 and 121763

Note: When ordering No. 121981, state width of hem and number of Hemmer for which it is required

HEMMERS ON SHANK

20163	23231	Feed Dog, 16 teeth (16 teeth to the inch), for 1/16 in. stitch, for 20123
35926	23231	Hemmer
590D	23231	" Adjusting Screw
1443B	23231	" Screw
35927	23231	" Shank
35540	23231	Hemmer on Shank complete with right hand lower guide, for lace, Nos. 1443B, 35926, 35927 and two 590D
62527	23231	Presser Foot Hinge Pin
40316	23231	" " Plate
40317	23231	" " Shank
40318	23231	Presser Foot (hinged) complete, for lace running, Nos. 40316, 40317 and 62527

HEMMERS

No.	Plate	Name
20123XC	23231	Throat Plate, for 20163
26603	23231	Feed Dog, 20 teeth (16 teeth to the inch), for 26605 and 26606
35236	23231	Hemmer on Shank, for 7/16 in. hem
52055	23231	Presser Foot
26605XC	23231	Throat Plate (large needle hole), for 26603
26606XC	-----	Throat Plate (small needle hole), for 26603
26603	23232	Feed Dog, 20 teeth (16 teeth to the inch), for 26605 and 26606
28627	23232	Hemmer on Shank, for 1/8 in. to 5/8 in. gauges
28628	23232	Presser Foot, for 3/8 in. to 5/8 in. gauges
26605XC	23232	Throat Plate (large needle hole), for 26603
26606XC	-----	Throat Plate (small needle hole), for 26603
120991	23232	Hemmer on Shank, for 1/16 in. to 1/4 in. hem
120367	23232	Hemmer on Shank, for handkerchief work

PIPING ATTACHMENT

44253	18315	Feed Dog, 16 teeth (16 teeth to the inch), for 44255 and 44256
120977	18315	Piping Attachment
1443J	18315	" " Screw
35245	18315	Piping Attachment complete, for piping house dresses, Nos. 1443J and 120977
52056	18315	Presser Foot
44256XC	18315	Throat Plate (large needle hole), for 44253
44255XC	-----	Throat Plate (small needle hole), for 44253

PRESSER FEET

36464	23236	Presser Foot Spring Guide
665J	23236	" " " " Screw
36465	23236	Presser Foot (right hand spring guide) with 665J and 36464, for 1/32 in. to 5/16 in. gauges

Note: When ordering No. 36464 or No. 36465, state required distance from edge of goods to seam.

28726	18372	Presser Foot (right hand spring guide) with 665J and 28725, for 1/32 in. to 1/4 in. gauges
-------	-------	--

PRESSER FEET

No.	Plate	Name
28725	18372	Presser Foot Spring Guide
Note: When ordering No.28725 or No.28726, state required distance from edge of goods to seam.		
26638	18372	Presser Foot (double toe), for gathering
12335	23236	Presser Foot (narrow)
12435	23236	" " with 228J (with needle hole on right hand side)
228J	23236	Presser Foot Extension Screw
36714	23236	" " with 233D
36715	23236	" " Guide (right) with 36716
233D	23236	" " Set Screw
36716	23236	" " Stud
36717	23236	Presser Foot complete with Adjustable Guide (right), Nos.36714 and 36715
270195	18372	Presser Foot, for gathering
270196	18372	" " " slide fasteners
36773	23236	" " " braiding
35528	23236	" " (wide)
120828	23236	" " (single toe), for gathering, for fine work
121763	23236	Presser Foot with 121981 with Hemmer with Yielding Top Scroll
20343	23236	Presser Foot with guide on bottom to the right of needle hole
12462	23236	Presser Foot, for 1/8 in. to 1 in. gauges
Note: When ordering No.12462, give width of turned edge from seam.		
12463	23236	Presser Foot with Strip Guide
36654	23236	" " for tucking shirt bosoms
40315	23236	" " " long stitch for general work
40322	23236	Presser Foot (narrow)
26276	23236	" " Hinge Pin
20133	23236	" " Plate
19223	23236	" " Shank
20134	23236	Presser Foot (hinged) complete, for 3/16 in. to 1/4 in. gauges, for collar and cuff work, Nos.19223, 20133 and 26276
7298	23236	Presser Foot Hinge Pin
20360	23236	" " Plate
19335	23236	" " Shank
20361	23236	Presser Foot (hinged) plain bottom complete, Nos.7298, 19335 and 20360
18055	18372	Presser Foot Hinge Pin
143213	18372	" " Plate
143216	18372	" " "
143209	18372	" " Shank
143217	18372	" " "
143317	18372	" " Yielding Plate
143318	18372	" " " "
143320	18372	" " " " Spring
143215	18372	Presser Foot (hinged) long toes with left hand Yielding Plate complete, Nos.18055, 143209, 143213, 143317 and 143320

PRESSER FEET

No.	Plate	Name
143219	18372	Presser Foot (hinged) long toes with right hand Yielding Plate complete, Nos.18055, 143216, 143217, 143318 and 143320

PRESSER FEET

WITH GRADUATED ADJUSTABLE GUIDES

35134	18359	Presser Foot with 36696
35002	18359	" " Extension
35003	18359	" " Graduated Adjustable Guide (long, left)
35004	18359	Presser Foot Graduated Adjustable Guide (long, right)
35005	18359	Presser Foot Graduated Adjustable Guide (short, right)
35006	18359	Presser Foot Graduated Adjustable Guide (short, right) flush
35135	18359	Presser Foot Graduated Adjustable Guide Clamp
35136	18359	Presser Foot Graduated Adjustable Guide Clamp Lever
337B	18359	Presser Foot Graduated Adjustable Guide Clamp Screw
36696	18359	Presser Foot Graduated Adjustable Guide Clamp Steady Pin
35137	18359	Presser Foot with Extension and Graduated Adjustable Guides complete, Nos.337B, 35002 to 35006 and 35134 to 35136

PRESSER FOOT EXTENSIONS

62527	23236	Presser Foot Hinge Pin
20155	23236	" " Plate
20156	23236	" " Shank
20157	23236	Presser Foot (hinged) complete, Nos. 228J, 20155, 20156 and 62527
26279	23236	Presser Foot Extension, 1/16 inch
26280	23236	" " " 1/8 inch
26281	23236	" " " 1/4 inch
26282	23236	" " " 3/8 inch
26283	23236	" " " 1/2 inch
228J	23236	" " " Screw

MISCELLANEOUS PARTS

No.	Plate	Name
143185	18347	Feed Bar Body with two each 1607C and 51220AL
51220AL	18347	Feed Bar Body Adjusting Screw
1607C	18347	" " " " " Lock Nut
704C	18347	" " " Screw
143186	18347	" " Shank
143187	18347	Feed Bar (tilting adjustable) complete, Nos. 704C, 143185 and 143186
228394	18347	Spool Pin

USED IN CONJUNCTION WITH THREAD UNWINDER

No.	Plate	Name
259370	18362	Spool Pin
259378	18362	" " " Arm with 217E and 259379
448AL	18362	" " " Set Screw
232896	18362	" " " Bracket with two 448AL
448AL	18362	" " " Set Screw
259371	18362	" " " Cap (bakelite)
1010F	18362	" " " Hinge Screw
259379	18362	" " " Retaining Spring
217E	18362	" " " Washer
259372	18362	" " " Screw
259373	18362	Spool Pin complete, Nos. 1010F and 259370 to 259372
60913	18362	Spool Weight with 60914
60914	18362	" " " Center Pin
225377	18362	" " " Wire, for small spools
27739	18362	Thread Cone (wood)
225390	18362	" " " Holder

PULLER FEED

No.	Plate	Name
259463	18342	Balance Wheel, belt grooves 2-1/8 and 1 in. diam., with 201346AL and 350107AL
259464	18342	Balance Wheel 259463 with 270004
259465	18342	" " belt grooves 2.9 in. outside diam., for 3/8 in. "V" belt and 1 in. bottom diam., for round belt, with 201346AL and 350107AL
259466	18342	Balance Wheel 259465 with 270004
350107AL	18342	" " Position Screw
201346AL	18342	" " Set Screw
259537	18342	Puller Feed Base with 200364C, 259061, two each 200902D and 205796
259649	18342	Puller Feed Base Block (wood) (for use where attachment is not set into the table)
200710	18342	Puller Feed Base Bolt
9842R	18342	" " " Washer
225190	18342	" " Driving Belt, size 1/4 in. diam., length 39-1/2 in., with 25128
25128	18342	Puller Feed Driving Belt Hook
237751	18342	" " " Gear with 200382C and 201220C
201220C	18342	Puller Feed Driving Gear Position Screw
200382C	18342	Puller Feed Driving Gear Set Screw
259057	18342	" " " Pinion
200095B	18342	" " " Cap Screw
259468	18342	" " " Pulley (belt groove 4-1/4 in. diam.) with 200373C
200373C	18342	Puller Feed Driving Pulley Set Screw
259469	18342	" " " " Shaft
259470	18342	" " " " " "
201188C	18342	Collar with 201188C
200364C	18342	Puller Feed Driving Pulley Shaft Collar Set Screw
259538	18342	Puller Feed Driving Pulley Shaft Set Screw
259470	18342	Puller Feed Roll and Shaft (lower) with 200364C
201188C	18342	Puller Feed Roll and Shaft (lower) Collar with 201188C
200364C	18342	Puller Feed Roll and Shaft (lower) Collar Set Screw
259539	18342	Puller Feed Roll and Shaft (lower) Extension Set Screw
*259061	-----	Puller Feed Roll and Shaft (upper)
200902D	18342	" " " " " " Bearing
		Puller Feed Roll and Shaft (upper) Bearing Screw

PULLER FEED

No.	Plate	Name
205796	18342	Puller Feed Roll and Shaft (upper) Bearing Spring
259063	18342	Puller Feed Roll and Shaft Gear with 200394C
200394C	18342	Puller Feed Roll and Shaft Gear Set Screw
259064	18342	Puller Feed Work Guide (wood)
259540	18342	Puller Feed Device complete, Nos. 200095B, 225190, 237751, 259057, 259064, 259464, 259468, 259469, 259537 to 259539, 259649 two each 9842R, 200710, 259063 and 259470

Note: Balance Wheel No. 259466, for Machines with "v" belt drive will be furnished with this Device complete in place of balance wheel No. 259464 if so specified on order.

THREAD UNWINDER

225257	18362	Spool Rest (for two spools) (flat) with 201018C
150203	18362	Spool Rest Cushion (felt)
225388	18362	" " Rod
200383C	18362	" " " Set Screw
201018C	18362	" " " Set Screw
259658	18362	" " Stand with 200383C
225391	18362	Thread Guide
201696H	18362	" " Lock Nut
225326	18362	" " Position Cup
225324	18362	" " Rod with 208AL and 225322
208AL	18362	Thread Guide Rod Screw
225322	18362	" " " Washer
225258	18362	Thread Unwinder (for two spools) complete, Nos. 201696H, 225257, 225324, 225326, 225388, 259658, two each 150203, 225391 and three wood screws 7/8 in., No. 12

TUCKER (Long Arm)

259541	18343	Presser Foot, 50 needle hole
259542	18343	" " 53 needle hole, 1/16 in. gauge to left of needle hole
259543	18343	Presser Foot, 53 needle hole, 3/32 in. gauge to left of needle hole
259544	18343	Presser Foot, 53 needle hole, 1/8 in. gauge to left of needle hole

TUCKER

No.	Plate	Name
259545	18343	Presser Foot, 53 needle hole, 5/32 in. gauge to left of needle hole
36387	18343	Space Guide
259529	18343	" " Base with 35512, 35514, 201525E, 225708, 350472H and two 1426E
350472H	18343	Space Guide Base Hinge Screw
201525E	18343	" " " " " " Nut
225708	18343	" " " Spring
35511	18343	" " Indicator
35512	18343	" " Pin
35513	18343	" " Stop (left)
35514	18343	" " " " Guide Pin
1426E	18343	" " " " Screw Stud
1657D	18343	" " " " Thumb Nut
17718	18343	" " " " " " "
		Washer
35515	18343	Space Guide Stop (right)
1426E	18343	" " " " " " Screw Stud
1657D	18343	" " " " " " Thumb Nut
17718	18343	" " " " " " " "
		Washer
50053W	18343	Space Guide Thumb Screw
259530	18343	Space Guide complete, Nos. 35511, 35513, 35515, 36387, 50053W, 259529, two each 1657D and 17718
35517	18343	Tuck Guide Arm
1177J	18343	" " " Screw
35518	18343	" " Base
50134E	18343	" " " Screw Stud
36389	18343	" " Bracket
307C	18343	" " " Screw Center
56814	18343	" " " " " " 307C
		with 1513J
1513J	18343	Tuck Guide Bracket Screw Center Nut
36390	18343	" " " " Spring
36391	18343	" " " " " " Plate
9D	18343	" " " " " " Screw
423C	18343	" " " " " " Stop Screw
1520J	18343	" " " " " " Nut
36392	18343	" " Frame
36393	18343	" " " Spring
1510E	18343	" " " " Nut
35524	18343	" " " " Washer
803C	18343	" " " Stop Screw
1520J	18343	" " " " " " Nut
35511	18343	" " Indicator
35525	18343	" " Plate
1115F	18343	" " Screw
36394	18343	Tuck Guide complete, Nos. 9D, 423C, 803C, 1510E, 35511, 35517, 35518, 35524, 35525, 36389 to 36393, 50134E, two each 1115F, 1177J, 1520J, 56814 and three wood screws 1-1/4 in., No. 10
259532	18343	Tucker (long arm) complete, Nos. 36394, 259530 and 259541

WOOD BASE

No.	Plate	Item
For Use with Tuck Folder		
228395	18361	Auxiliary Knee Lifter Rock Lever Rod with 227785
228396	18361	Auxiliary Knee Lifter Rock Lever Rod Bracket
*227785	-----	Auxiliary Knee Lifter Rock Lever Rod Cap
79627	18361	Bench Stand Section (back) with two each 20022, 27878, 150962 and wood screws 3-1/2 in., No. 14
79626	18361	Bench Stand Section (front) with wood screw 1-1/2 in., No. 12, two each 20022, 27878 and wood screws 3-1/2 in., No. 14
44243	18361	Machine Hinge Connection
2809	18361	" " " Hinge Pin
33887	18361	" " Plate
150962	18361	Machine Hinge complete, Nos. 2809, 33887, 44243 and wood screw 1 in., No. 14, F.H. blacked
20022	18361	Machine Rest (felt)
27878	18361	" " Rivet
79628	18361	Bench Stand (sectional) complete, Nos. 79626 and 79627

FITTINGS

FOR BUTTON STAYS

26603	18315	Feed Dog, 20 teeth (16 teeth to the inch), for 26605 and 26606
121653	18315	Hemmer on Shank, for 9/16 in. hem
7298	18315	Presser Foot Hinge Pin
120143	18315	" " Plate
19335	18315	" " Shank
120144	18315	Presser Foot (hinged) complete, Nos. 7298, 19335 and 120143
26605XC	18315	Throat Plate (large needle hole), for 26603
26606XC	-----	Throat Plate (small needle hole), for 26603

FOR CHAINING OFF

No.	Plate	Item
142067	18374	Feed Dog, 21 teeth (20 teeth to the inch), for 142060 and 142061
142068	18374	Feed Dog, 17 teeth (18 teeth to the inch), for general and shirt work, for 142060
62527	18374	Presser Foot Hinge Pin
142058	18374	" " Plate
121344	18374	" " Shank
121945	18374	" " Spring
142059	18374	Presser Foot (spring hinged) complete, Nos. 62527, 121344, 121945 and 142058
142060	18374	Throat Plate (small needle hole), for 142067 and 142062
142061	18374	Throat Plate (large needle hole), for 142067 and 142062

FOR COLLAR WORK

(FIRST STITCHING)

20164	23219	Feed Dog, 18 teeth (16 teeth to the inch), for 1/8 in. stitch, for 52190
52189	23219	Presser Foot (solid)
52190XC	23219	Throat Plate, for 20164

FOR COLLAR WORK

(SECOND STITCHING)

121646	23219	Feed Dog, 12 teeth (16 teeth to the inch), for 121649
121647	23219	Presser Foot with 121648 and two 337J, for 3/16 in., 7/32 in., 1/4 in., 9/32 in. and 5/16 in. gauges
121648	23219	Presser Foot Edge Guide, for 3/16 in., 7/32 in., 1/4 in., 9/32 in. and 5/16 in. gauges
337J	23219	Presser Foot Edge Guide Screw
121649XC	23219	Throat Plate, for 121646

FOR COLLAR AND CUFF WORK

No.	Plate	Name
20163	23219	Feed Dog, 16 teeth (16 teeth to the inch), for 1/16 in. stitch
20164	23219	Feed Dog, 16 teeth (16 teeth to the inch), for 1/8 in. stitch
52188	23219	Presser Foot (solid), for cuff work
52189	23219	" " " " collar work
20123XC	23219	Throat Plate, for 20163 and 20164

FOR CUFF WORK

20164	23220	Feed Dog, 16 teeth (16 teeth to the inch), for 1/8 in. stitch, for 20160
52188	23220	Presser Foot (solid)
52190XC	23220	Throat Plate, for 20164

FOR CURTAIN WORK

143165	23220	Feed Dog, 18 teeth (14 teeth to the inch)
26276	23220	Presser Foot Hinge Pin
143166	23220	" " Plate
143167	23220	" " Shank
52544	23220	" " Spring
143168	23220	Presser Foot (spring hinged) complete, Nos. 26276, 52544, 143166 and 143167
143169XC	23220	Throat Plate (large needle hole)

FOR GENERAL WORK

143174	23220	Feed Dog, 17 teeth (14 teeth to the inch), for 143175
143175XC	23220	Throat Plate (large needle hole), for 143174
52031	23221	Feed Dog, 19 teeth (22 teeth to the inch), for 52032 and 52033
62527	23221	Presser Foot Hinge Pin
24544	23221	" " Plate
24982	23221	" " Shank
26231	23221	" " Spring

No.	Plate	Name
24982	23221	Presser Foot (spring hinged) complete, Nos. 24544, 24982, 26231 and 62527
52032XC	-----	Throat Plate (large needle hole), for 52031
52033XC	23221	Throat Plate (small needle hole), for 52031
127229	23221	Feed Dog, 17 teeth (14 teeth to the inch), for 127238
62527	23221	Presser Foot Hinge Pin
127233	23221	" " Plate
52390	23221	" " Shank
26231	23221	" " Spring
127234	23221	Presser Foot (spring hinged) complete, Nos. 26231, 52390, 62527 and 127233
131256	23221	Presser Foot Hinge Pin
127257	23221	" " Plate
127258	23221	" " Shank with 665J
127259	23221	" " Thread Cutter
239E	23221	" " " " Screw
127260	23221	Presser Foot (hinged) complete with Thread Cutter, Nos. 239E, 127257, 127259 and 131256
127238XC	23221	Throat Plate, for 127229
127087	23221	Feed Dog, 19 teeth (16 teeth to the inch), for 127106 and 127107
127106XC	23221	Throat Plate (large needle hole), for 127087
127107XC	-----	Throat Plate (small needle hole), for 127087
121446	23222	Feed Dog, spiked teeth, 13 teeth (10 teeth to the inch), for 20356, 20357 and 270128
20356XC	23222	Throat Plate (large needle hole), for 121446
20357XC	-----	Throat Plate (small needle hole), for 121446
44158	23222	Feed Dog, 15 teeth (14 teeth to the inch), for 44162
26276	23222	Presser Foot Hinge Pin
44159	23222	" " Plate
44160	23222	" " Shank
44161	23222	Presser Foot (hinged) complete, Nos. 26276, 44159 and 44160
44162XC	23222	Throat Plate, for 44158
20117	18345	Feed Dog, for shirt work, beveled, for hemmer, 16 teeth (16 teeth to the inch)
20124XC	18345	Throat Plate (large needle hole), for 20117
127087	23221	Feed Dog, 19 teeth (16 teeth to the inch), for 270127
270127	18345	Throat Plate (large needle hole), for 127087
121446	23228	Feed Dog, spiked teeth, 13 teeth (10 teeth to the inch), for 270128
270128	18345	Throat Plate (large needle hole), for 121446

FITTINGS

No.	Plate	Name
44252	23224	Feed Dog, 12 teeth (12 teeth to the inch), for 270129
44253	23224	Feed Dog, 16 teeth (16 teeth to the inch), for 270129
270129	18345	Throat Plate (large needle hole), for 44252 and 44253
270130	18345	Throat Plate (large needle hole), for 26603

FOR HEMMING BOTTOM OF DRESS SHIRTS

270121	18374	Feed Dog, for 270122
270120	18374	Hemmer Foot, 1/8 in. hem
270134	18374	" " 5/32 in. hem
270136	18374	" " 3/16 in. hem
270122	18374	Throat Plate, small needle hole, for 270121

FOR QUILTING

270114	18359	Presser, Bar Bushing (for use with Quilter 120485)
120479	18359	Quilter Guide (left)
120480	18359	" " (right)
120481	18359	" " Bracket
120482	18359	" " " 120481 with 120483 and two 209AL
209AL	18359	Quilter Guide Bracket Screw
120483	18359	" " Disengaging Sleeve
209AL	18359	" " " " Set Screw
120484	18359	Quilter Guide Disengaging Sleeve Spring
602D	18359	Quilter Guide Disengaging Sleeve Spring Screw
120485	18359	Quilter complete, Nos. 602D, 120479, 120480, 120482 and 120484

FOR SHIRT WORK

143170	23222	Feed Dog, 16 teeth (16 teeth to the inch), for 143171
143171XC	23222	Throat Plate (large needle hole), for 143170

FITTINGS

No.	Plate	Name
20159	18316	Feed Dog, 16 teeth (16 teeth to the inch), for 20160
143172	18316	Feed Dog, 18 teeth (18 teeth to the inch), for 20160
143173	18316	Feed Dog, 20 teeth (20 teeth to the inch), for 20160
20160XC	18316	Throat Plate (large needle hole), for 20159, 143172 and 143173
26603	23224	Feed Dog, 20 teeth (16 teeth to the inch), for 26605, 26606 and 270130
7298	23224	Presser Foot Hinge Pin
19334	23224	" " Plate
19335	23224	" " Shank
19336	23224	Presser Foot (hinged) complete, Nos. 7298, 19334 and 19335
26605XC	23224	Throat Plate (large needle hole), for 26603
26606XC	-----	Throat Plate (small needle hole), for 26603
142057	18360	Feed Dog, 21 teeth (22 teeth to the inch), for 142060
62527	18360	Presser Foot Hinge Pin
142058	18360	" " Plate
121944	18360	" " Shank
121945	18360	" " Spring
142059	18360	Presser Foot (spring hinged) complete, Nos. 62527, 121944, 121945 and 142058
142060	18360	Throat Plate (small needle hole), for 142057

FOR SHOULDER JOININGS

26603	23224	Feed Dog, 20 teeth (16 teeth to the inch), for 26605 and 26606
121662	23224	Joining Attachment with 121844
121844	-----	" " Shank, for 121662
121663	23224	Presser Foot
26605XC	23224	Throat Plate (large needle hole), for 26603
26606XC	-----	Throat Plate (small needle hole), for 26603

FOR SLEEVE PLACKETS (Facing)

121655	23225	Binder on Shank
26603	23225	Feed Dog, 20 teeth (16 teeth to the inch), for 26605 and 26606
121656	23225	Presser Foot

FITTINGS

No.	Plate	Name
26605XC	23225	Throat Plate (large needle hole), for 26603
26606XC	-----	Throat Plate (small needle hole), for 26603

FOR TAILOR WORK

44252	23224	Feed Dog, 12 teeth (12 teeth to the inch), for 44255 and 44256
44253	23224	Feed Dog, 16 teeth (16 teeth to the inch), for 44255 and 44256
36574	23224	Presser Foot
36575	23224	" " 36574 with 36576 and two 50202J
36576	23224	Presser Foot Finger Guard
50202J	23224	" " " " Screw
44256XC	23224	Throat Plate (large needle hole), for 44252 and 44253
44255XC	-----	Throat Plate (small needle hole), for 44252 and 44253
44136	23225	Feed Dog, 15 teeth (16 teeth to the inch), for 44137
12142	23225	Presser Foot
20458	23225	" "
44137XC	23225	Throat Plate, for 44136
52462	23226	Feed Dog, 19 teeth (22 teeth to the inch), for 52463
52463XC	23226	Throat Plate, for 52462

FOR YOKING

121658	23226	Edge Folder with Edge Guide on Shank
26603	23226	Feed Dog, 20 teeth (16 teeth to the inch), for 26605 and 26606
7298	23226	Presser Foot Hinge Pin
121659	23226	" " Plate
19223	23226	" " Shank
121660	23226	Presser Foot (hinged) complete, Nos. 7298, 19223 and 121659
26605XC	23226	Throat Plate (large needle hole), for 26603
26606XC	-----	Throat Plate (large needle hole), for 26603

NUMERICAL LIST OF PARTS

No.	Plate	Name
9D	18343	Tucker Tuck Guide Bracket Spring Screw, for 36394
176J	18393	Presser Foot Screw, for 270269
190D	23226	Binder Ribbon Tension Screw, for 26250
190D	23228	Corder Cord Guide Screw, for 120207
193D	18359	Binder Folder Screw, for 28776
207F	23226	" " " " 26250
207D	18373	Tape Reel Arm Screw, for 259784
208AL	18362	Thread Unwinder Thread Guide Rod Screw, for 225324
209AL	18359	Quilter Guide Bracket Screw, for 120482
209AL	18359	" " Disengaging Sleeve Set Screw, for 120482
217E	18362	Thread Unwinder Spool Pin Retaining Spring Screw, for 259378
228J	23236	Presser Foot Extension Screw, for 12435 and 20157
233J	18359	Binder Ribbon Tension Screw, for 28776
233D	23236	Presser Foot Guide Set Screw, for 36714
239E	23221	" " Thread Cutter Screw, for 127260
307C	18343	Tucker Tuck Guide Bracket Screw Center, for 56814
337J	23219	Presser Foot Edge Guide Screw, for 121647
337B	18359	Presser Foot Graduated Adjustable Guide Clamp Screw, for 35137
401D	18394	Rotary Take-up (large) Screw
423C	18343	Tucker Tuck Guide Bracket Stop Screw, for 36394
446C	18394	Thread Take-up Spring Regulator Set Screw
448AL	18362	Thread Unwinder Spool Pin Arm Bracket Set Screw, for 232896
448AL	18362	Thread Unwinder Spool Pin Arm Set Screw, for 232896
457AL	23228	Corder Cord Guide Bed Leveling Screw, for 120206
590D	23231	Hemmer Adjusting Screw, for 35540
591F	18379	Rotating Hook Bobbin Case Tension Spring Regulating Screw, for 52236
592E	18379	Rotating Hook Bobbin Case Latch Stop Screw, for 52237
602D	18359	Quilter Guide Disengaging Sleeve Spring Screw, for 120485
665J	18372	Presser Foot Spring Guide Screw, for 28726, 36465 and 127258
691F	18392	Throat Plate Screw
704C	18347	Feed Bar Body Screw, for 143187

From the Library of: National Needle Center

18287 - 1/2

228476



259477



41400



120342

25878

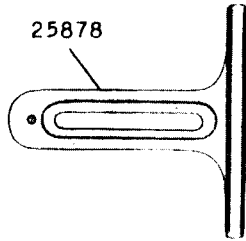

120343

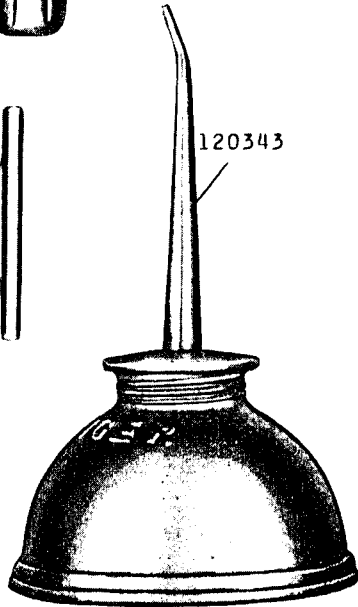

12361

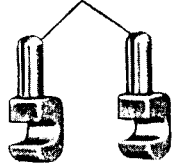

18305 - 3/8

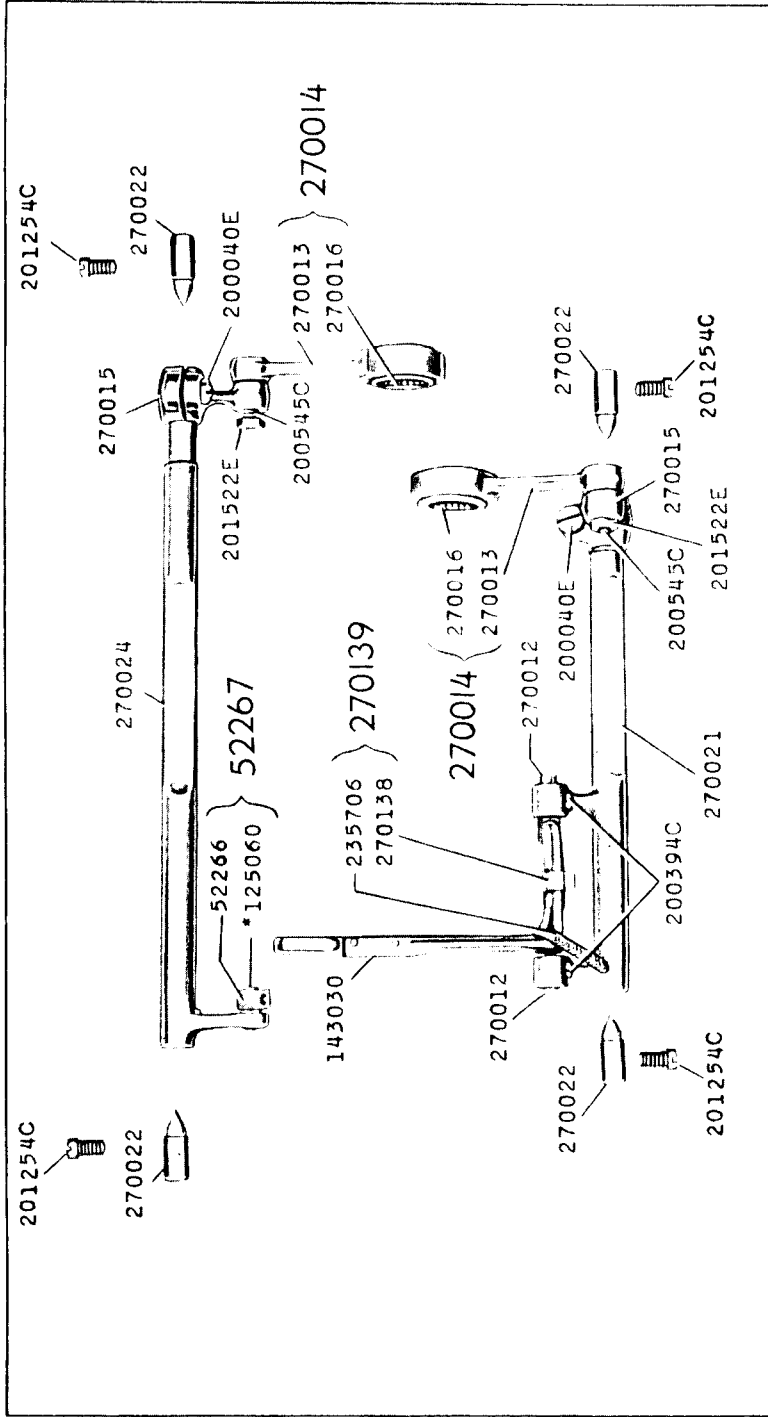

18312 - 3/8

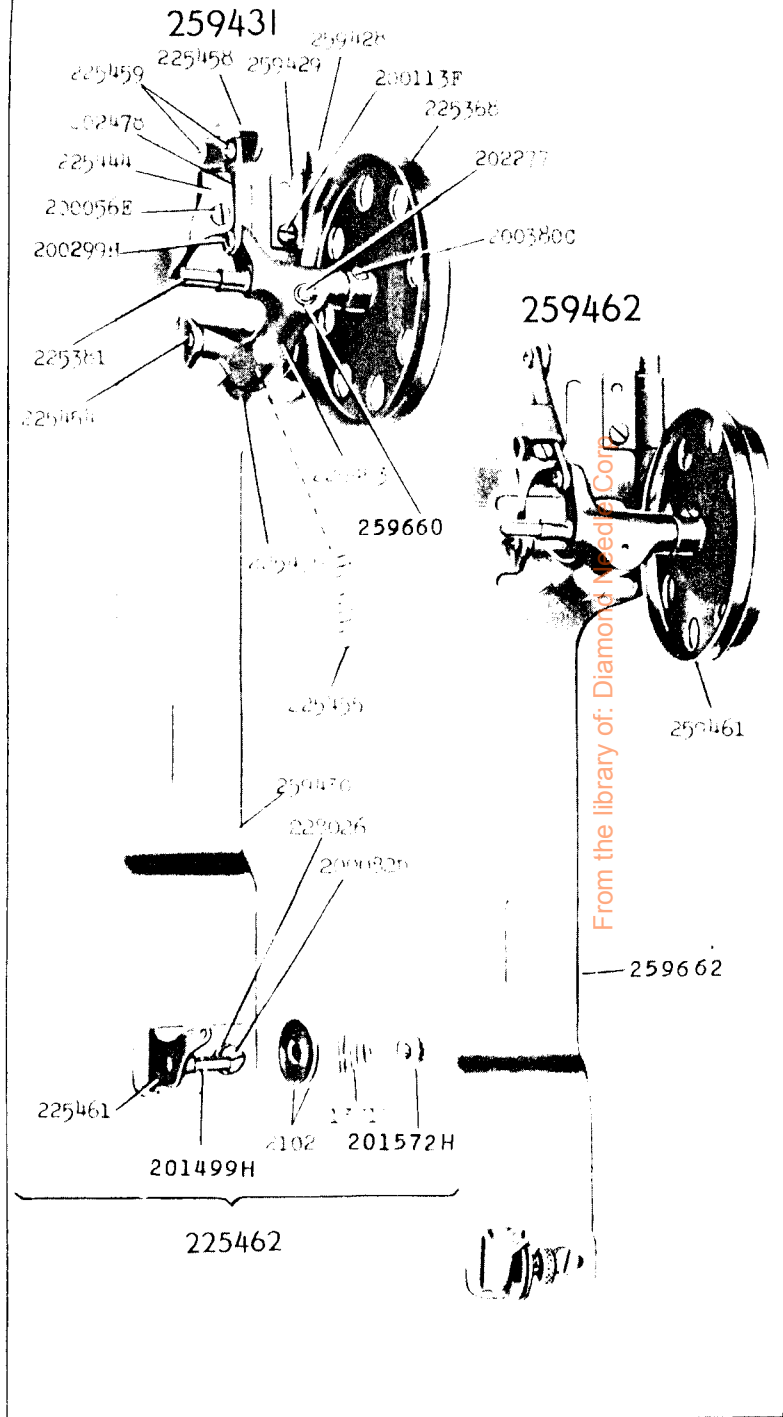

From the library of: Diamond Need Corp

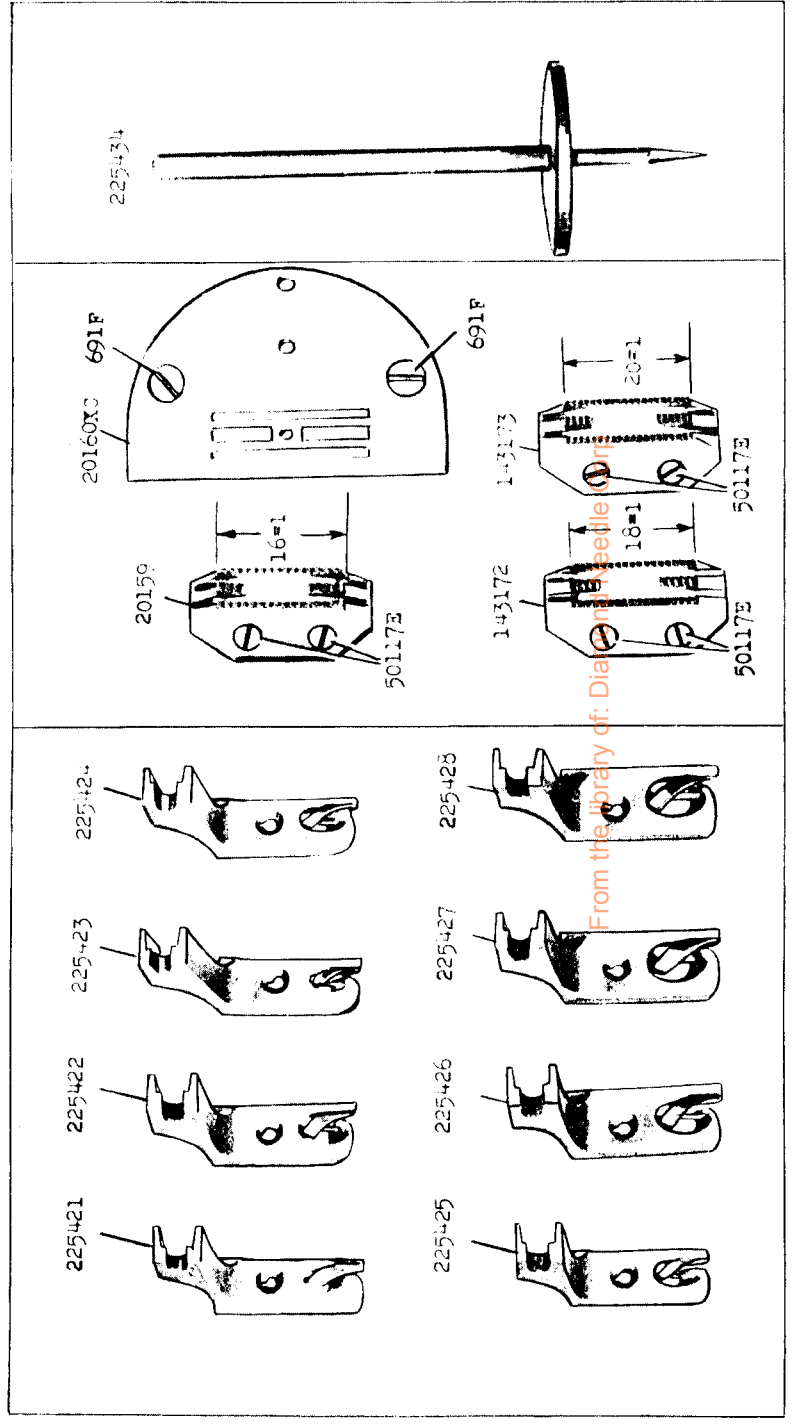
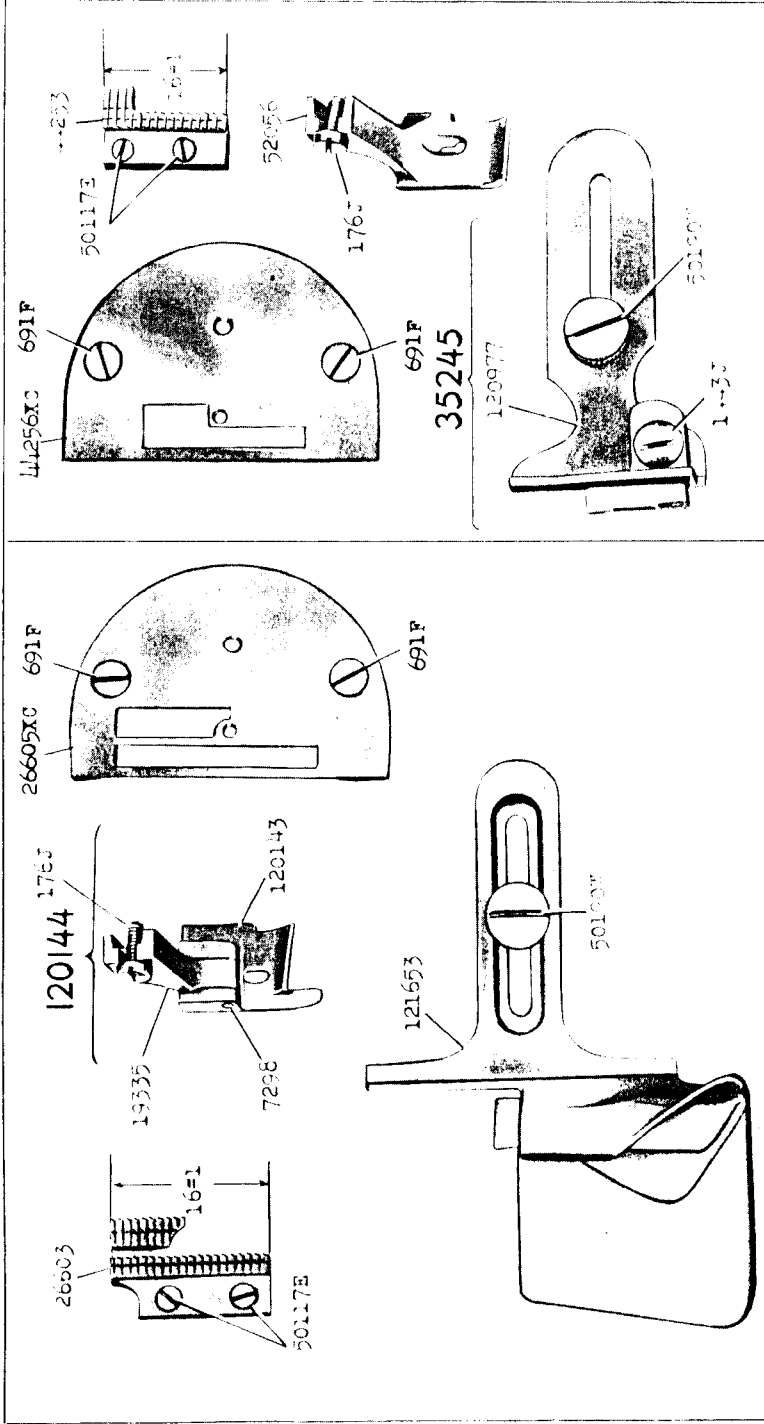

From the Library of: [Diana M. Beele](#)

18332 - 3/8

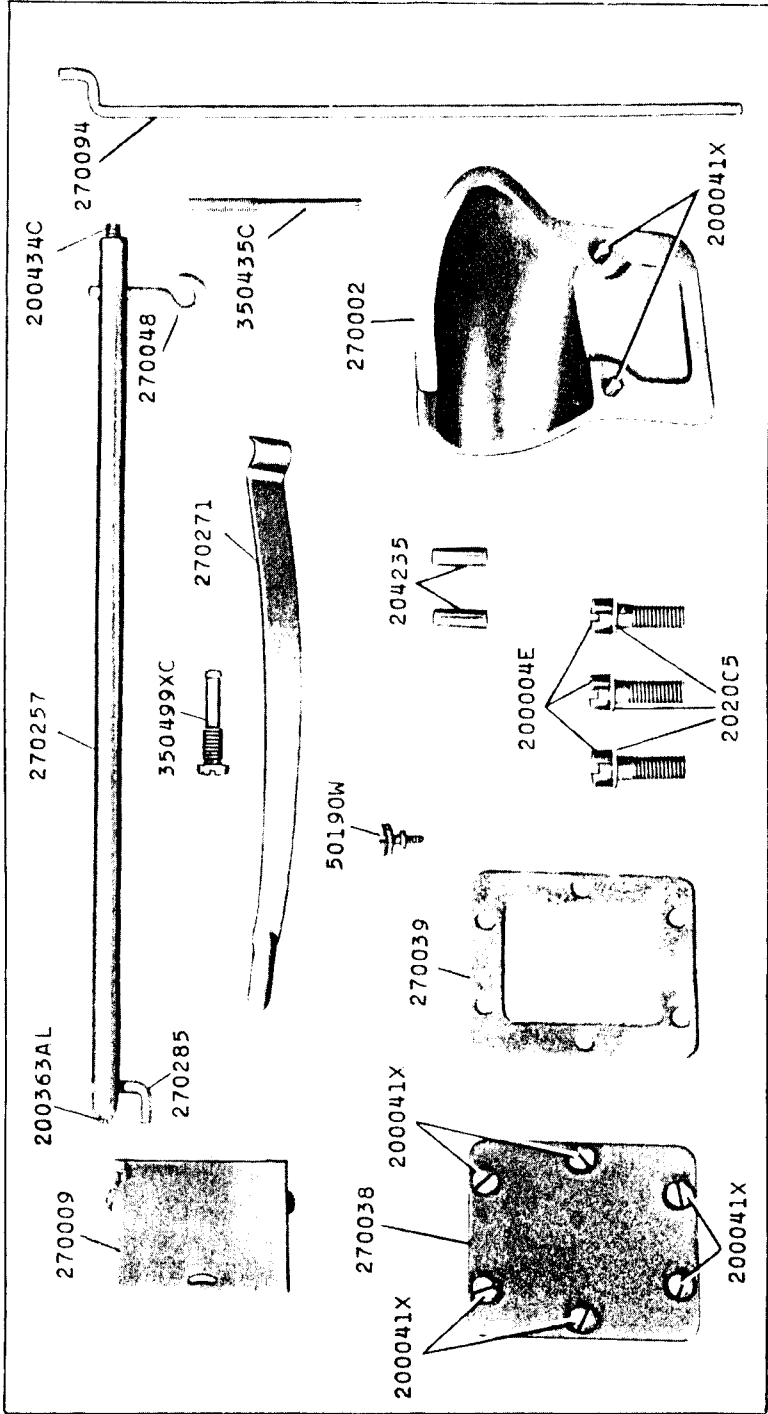

18333 - 1/4

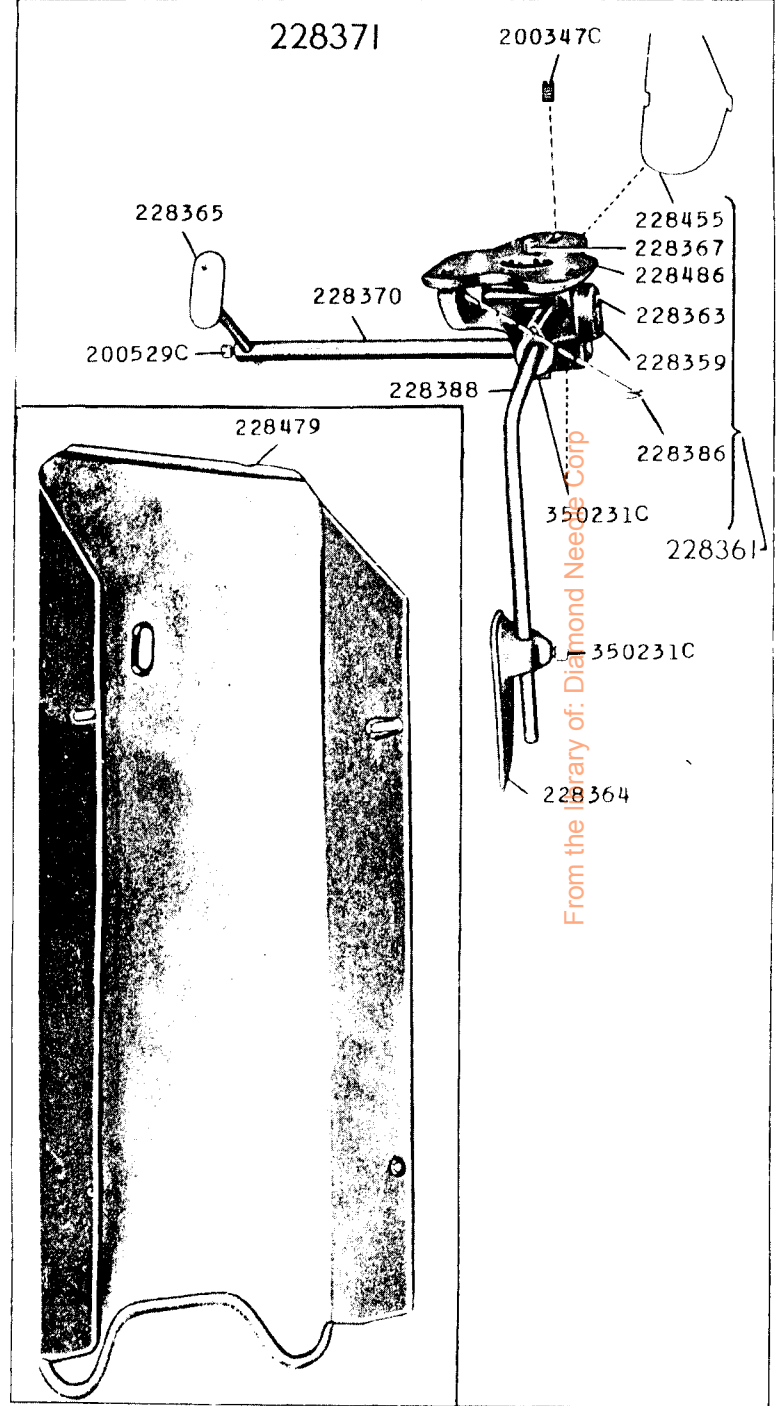

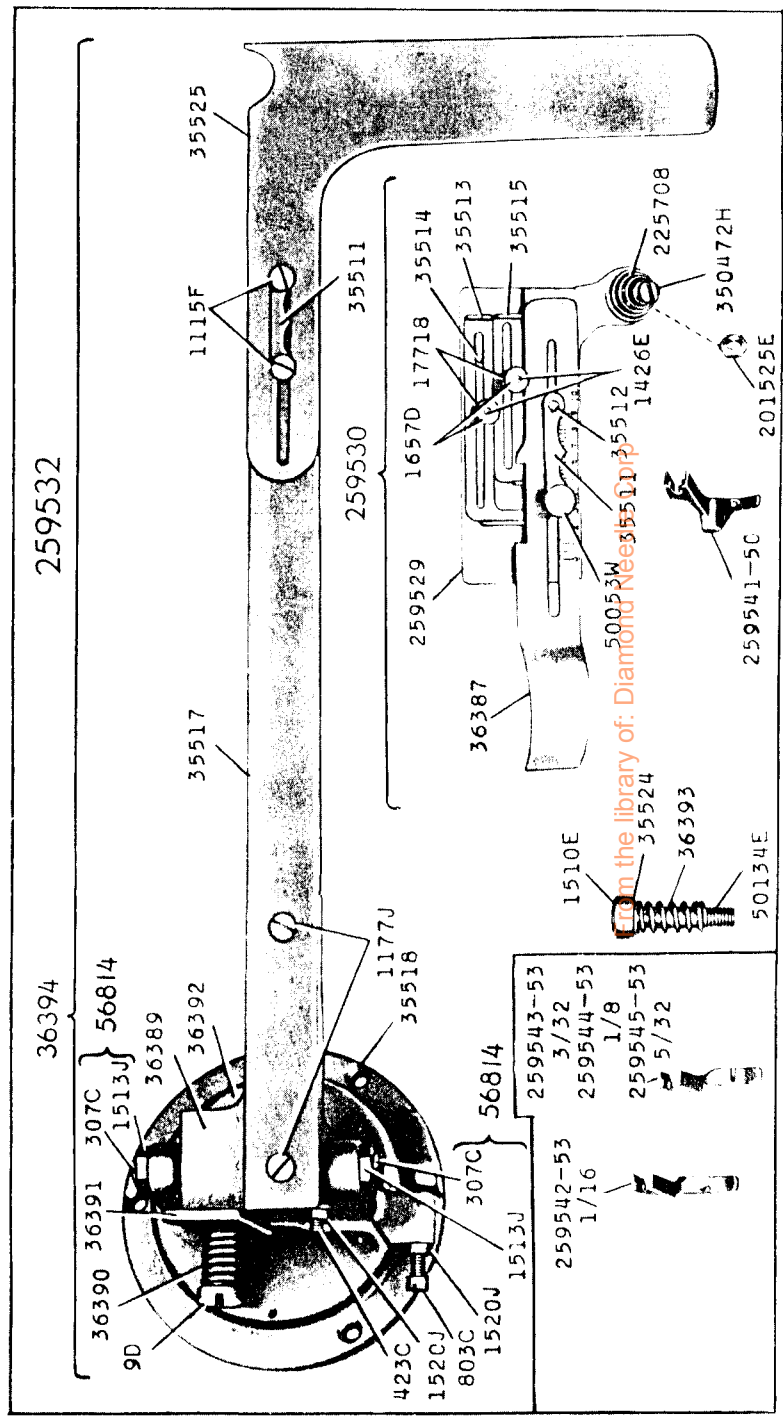
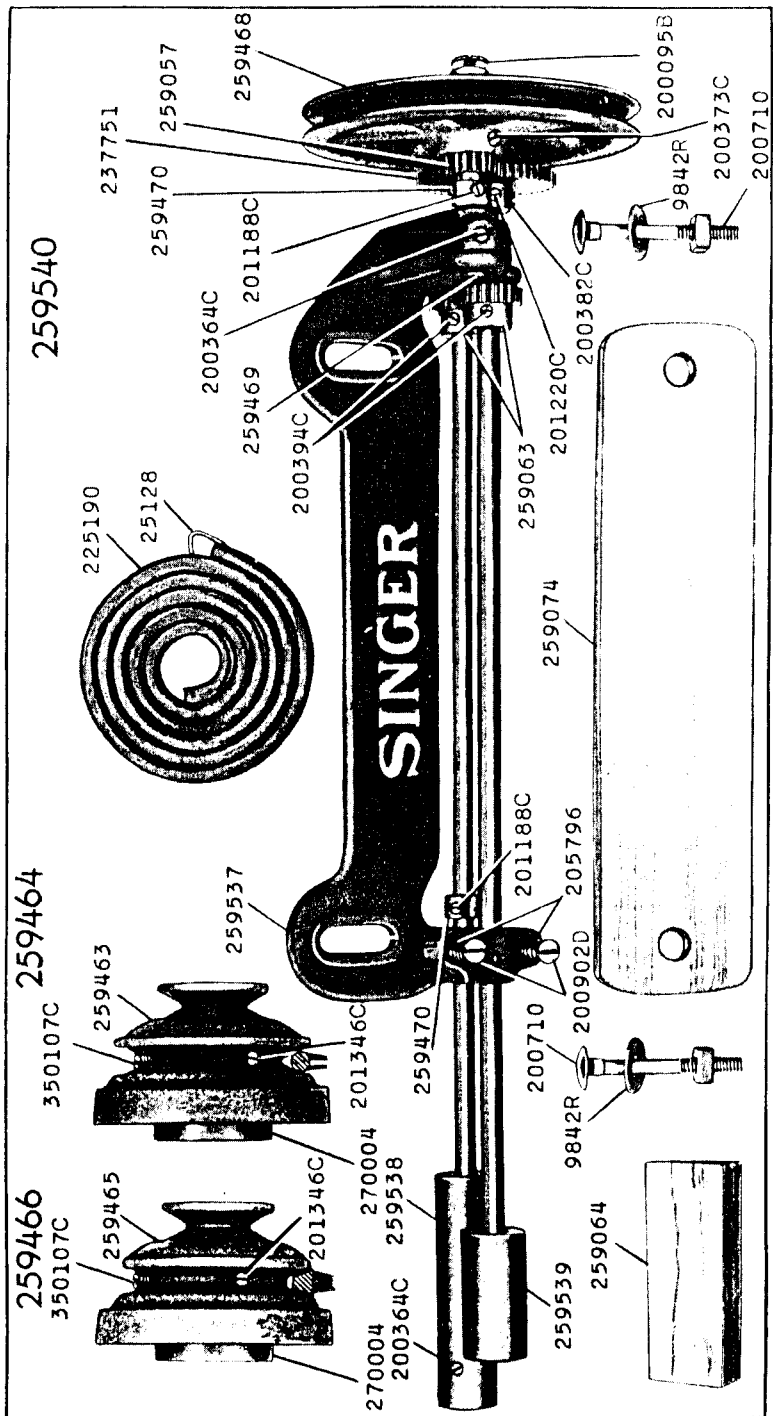

18359 - 1/2

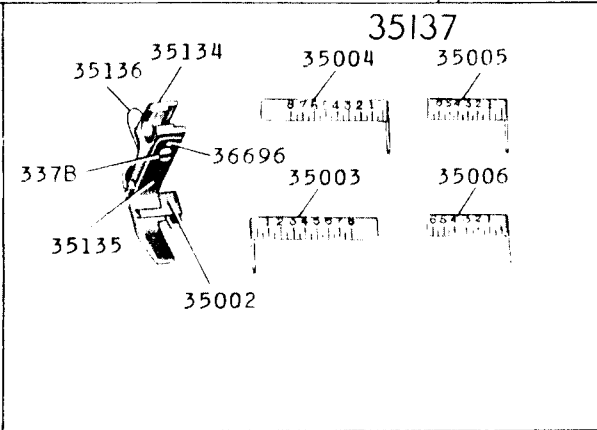
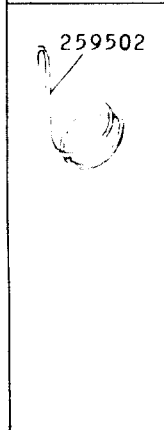
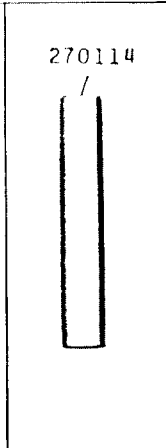
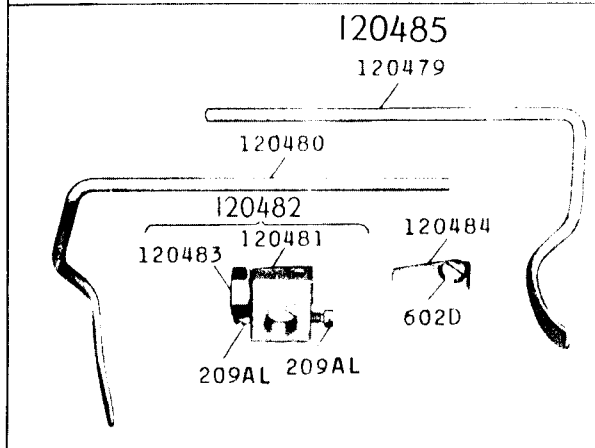
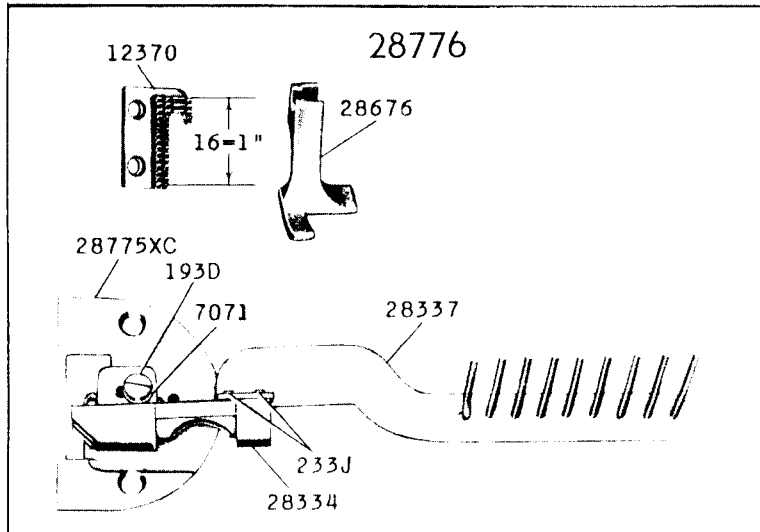

18360 - 2/3

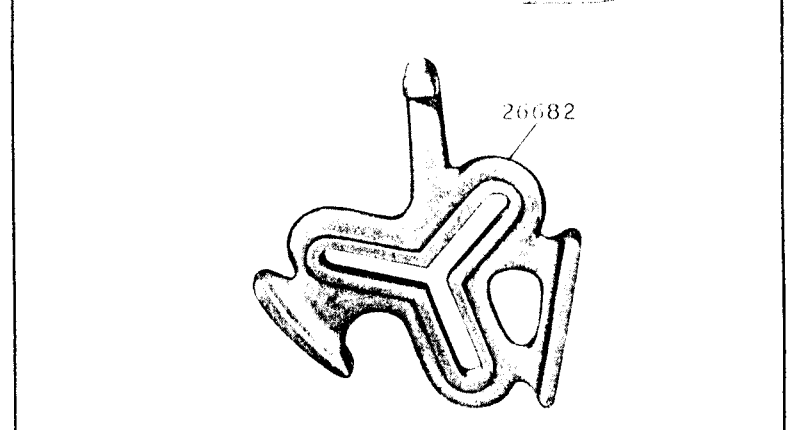
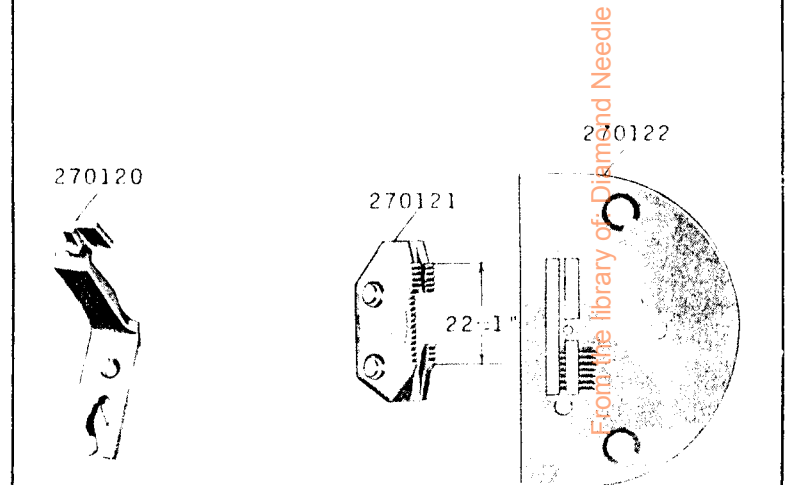
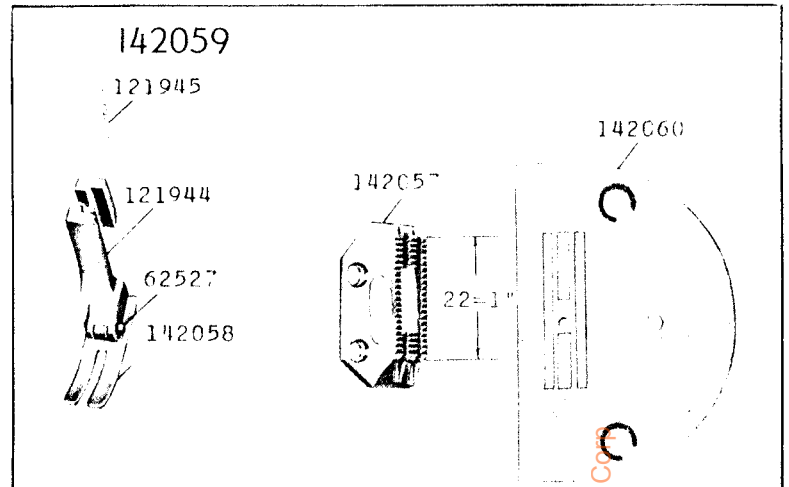

From the library of Diamond Needle Co.

18361 - 1/4

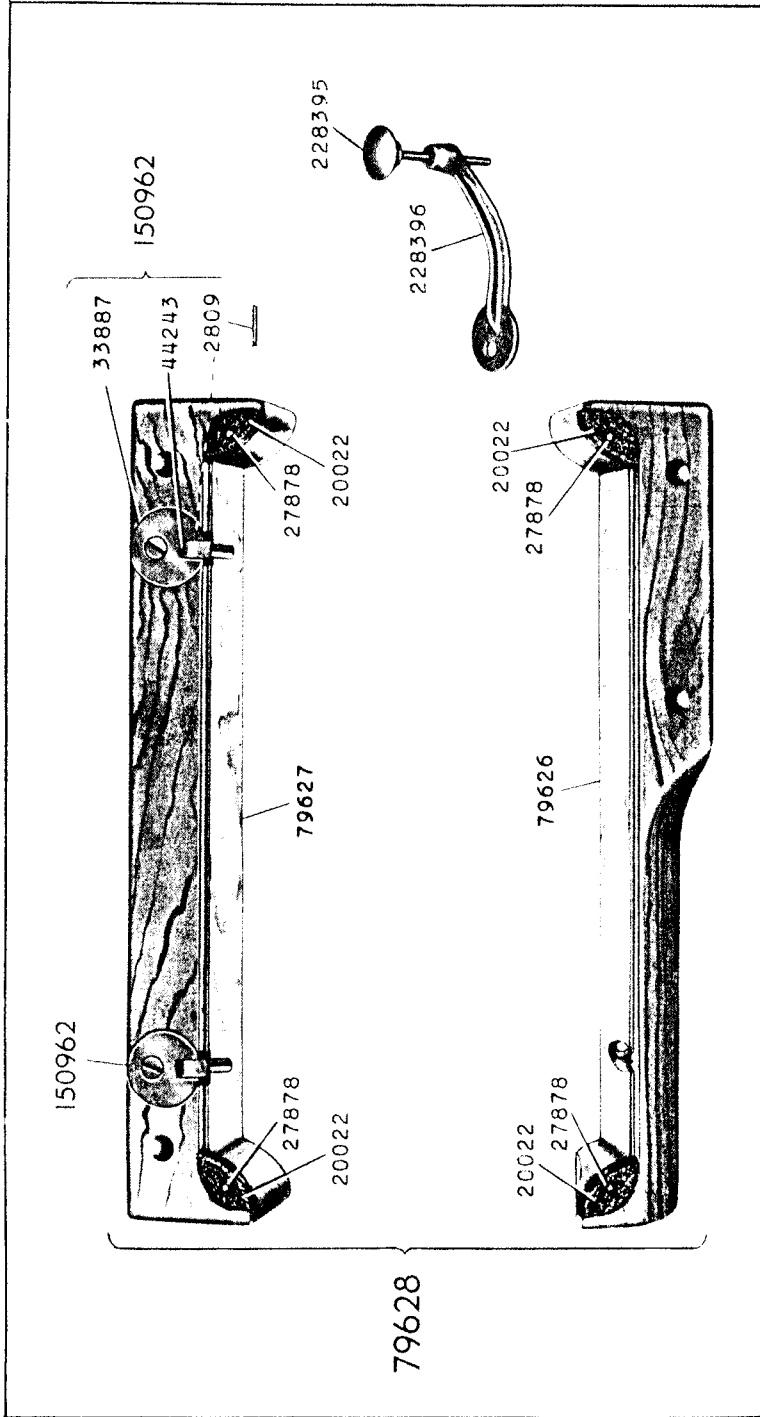

18362 - 1/6

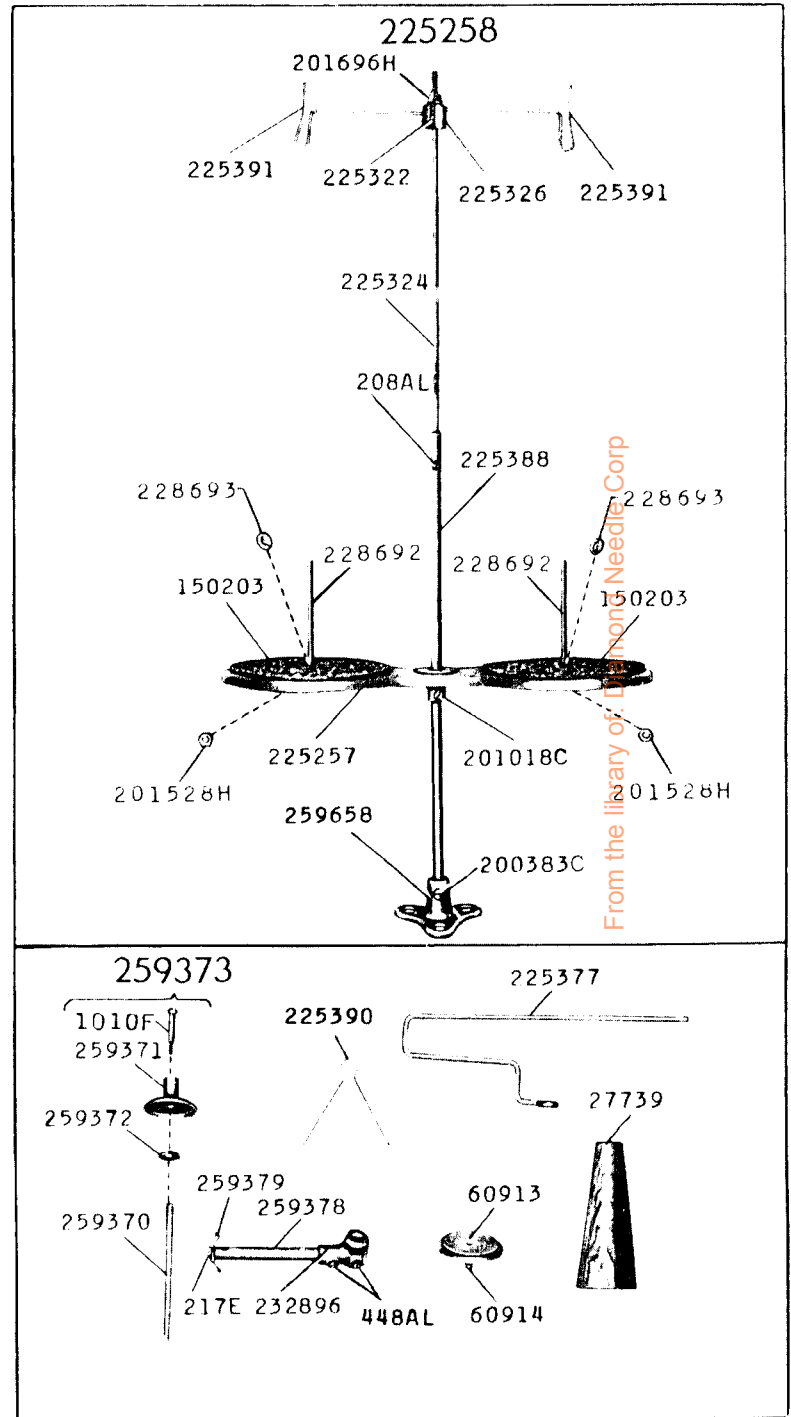

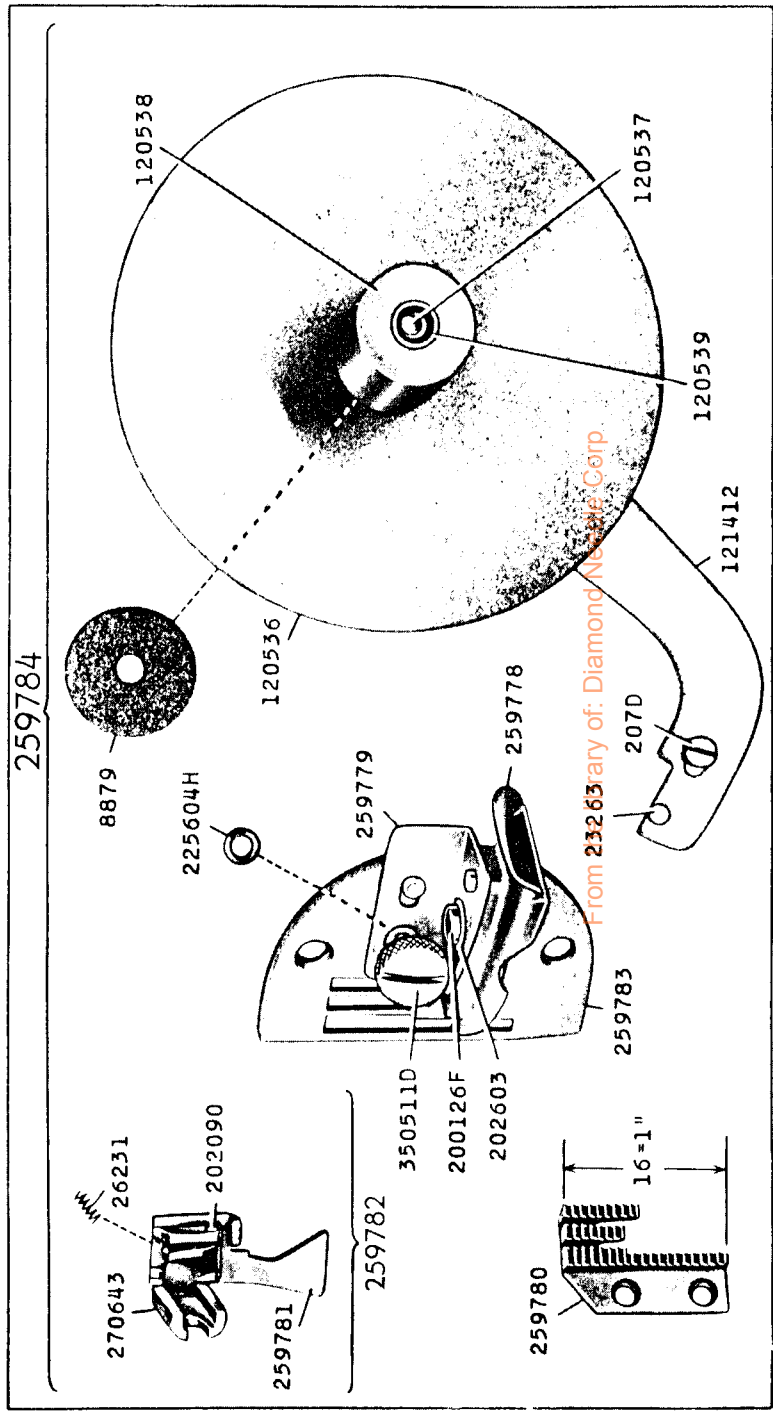
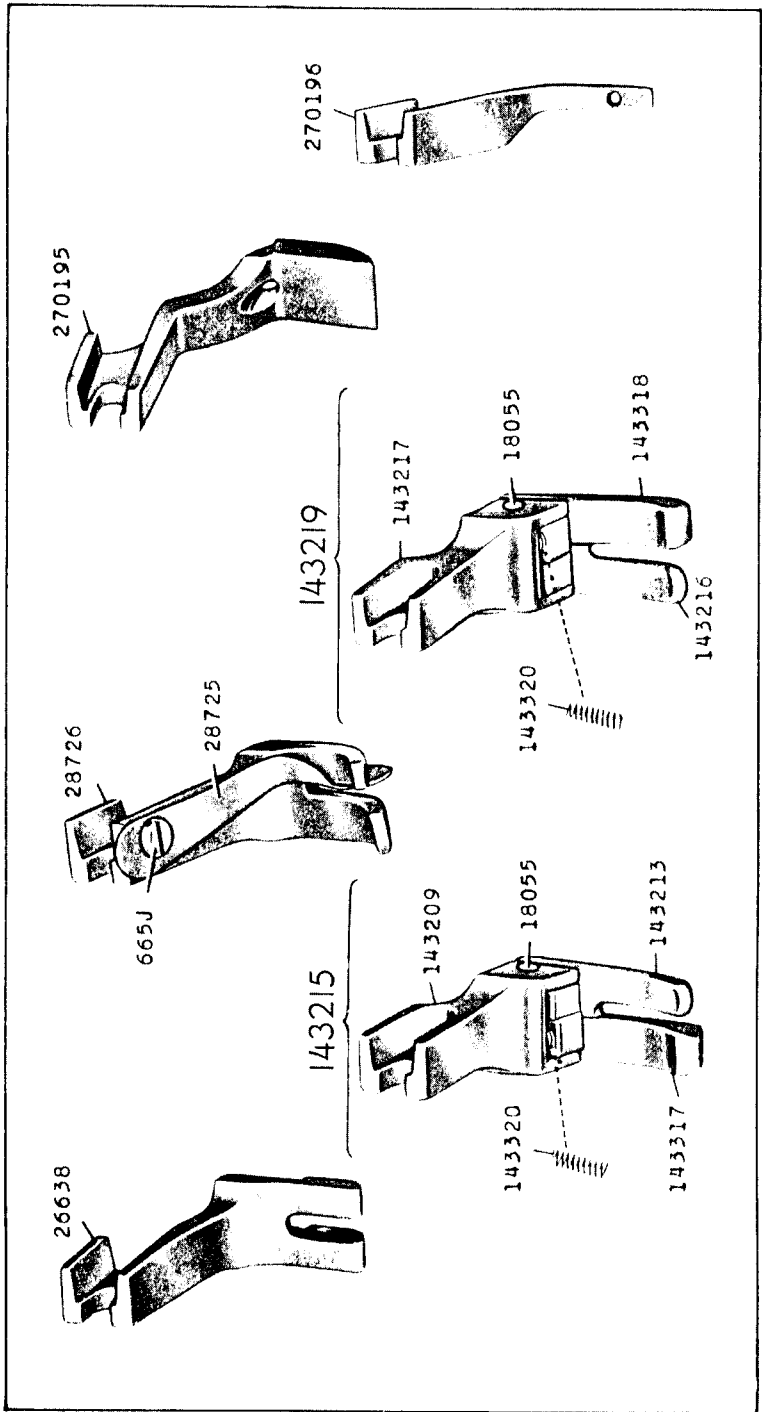

18374 - 2/3

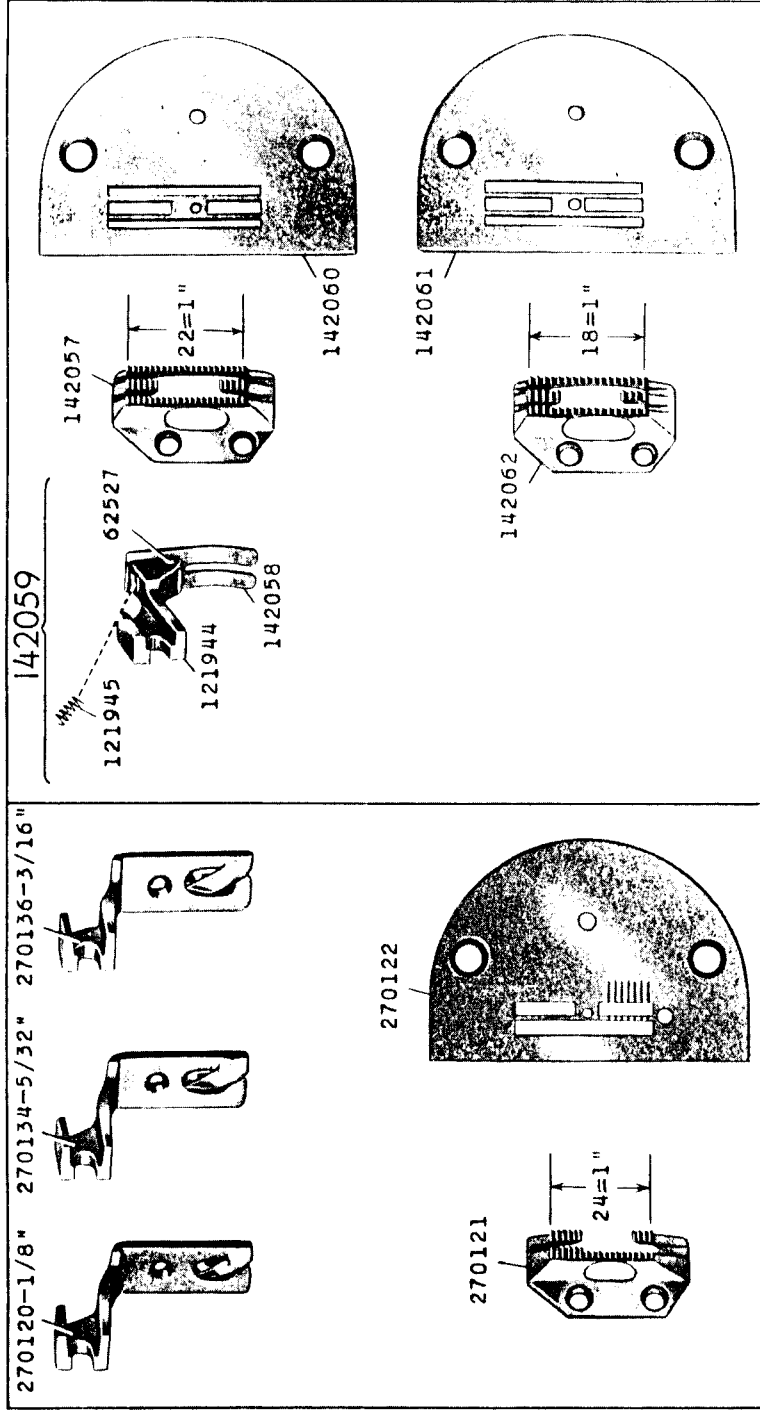

18375 - 2/3

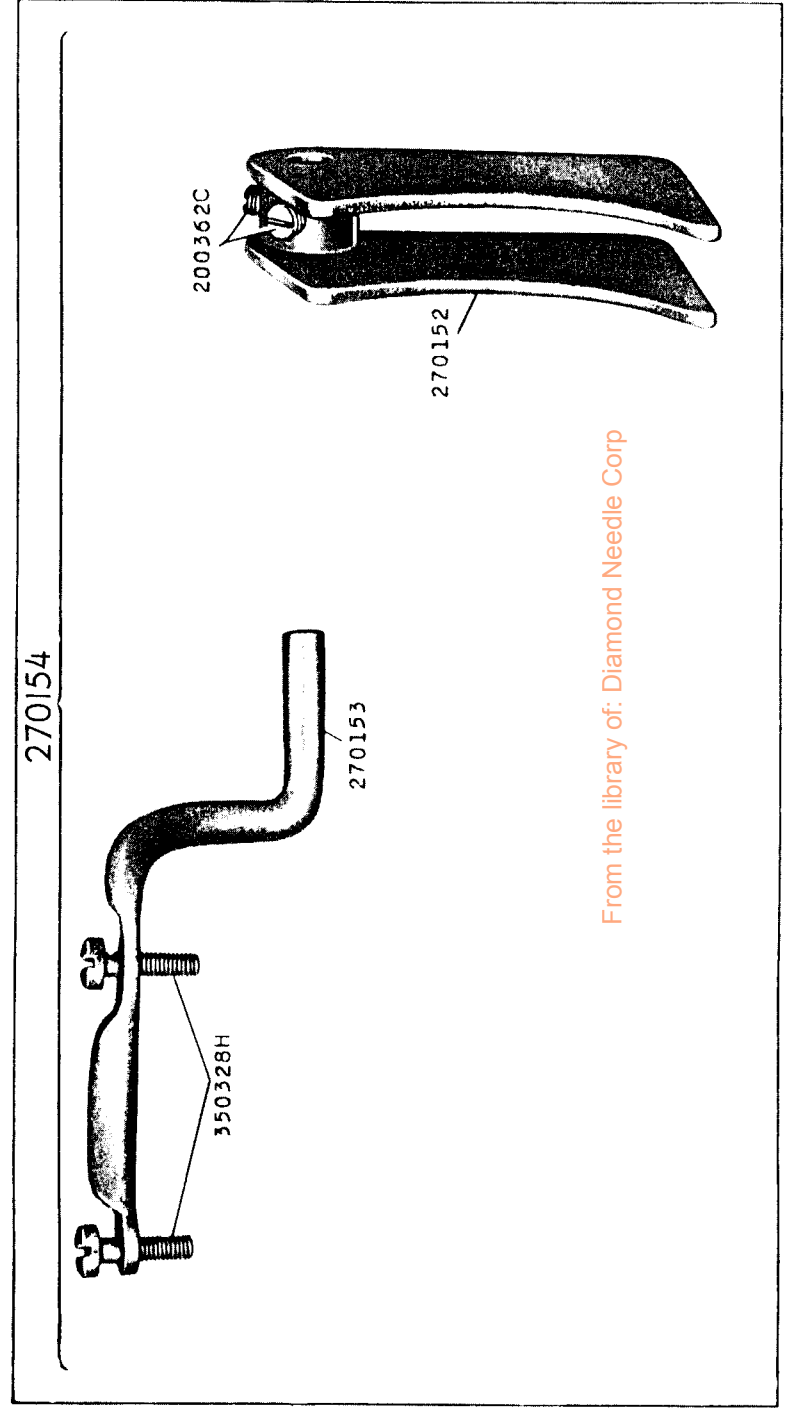

From the library of: Diamond Needle Corp

18379 - 3/4

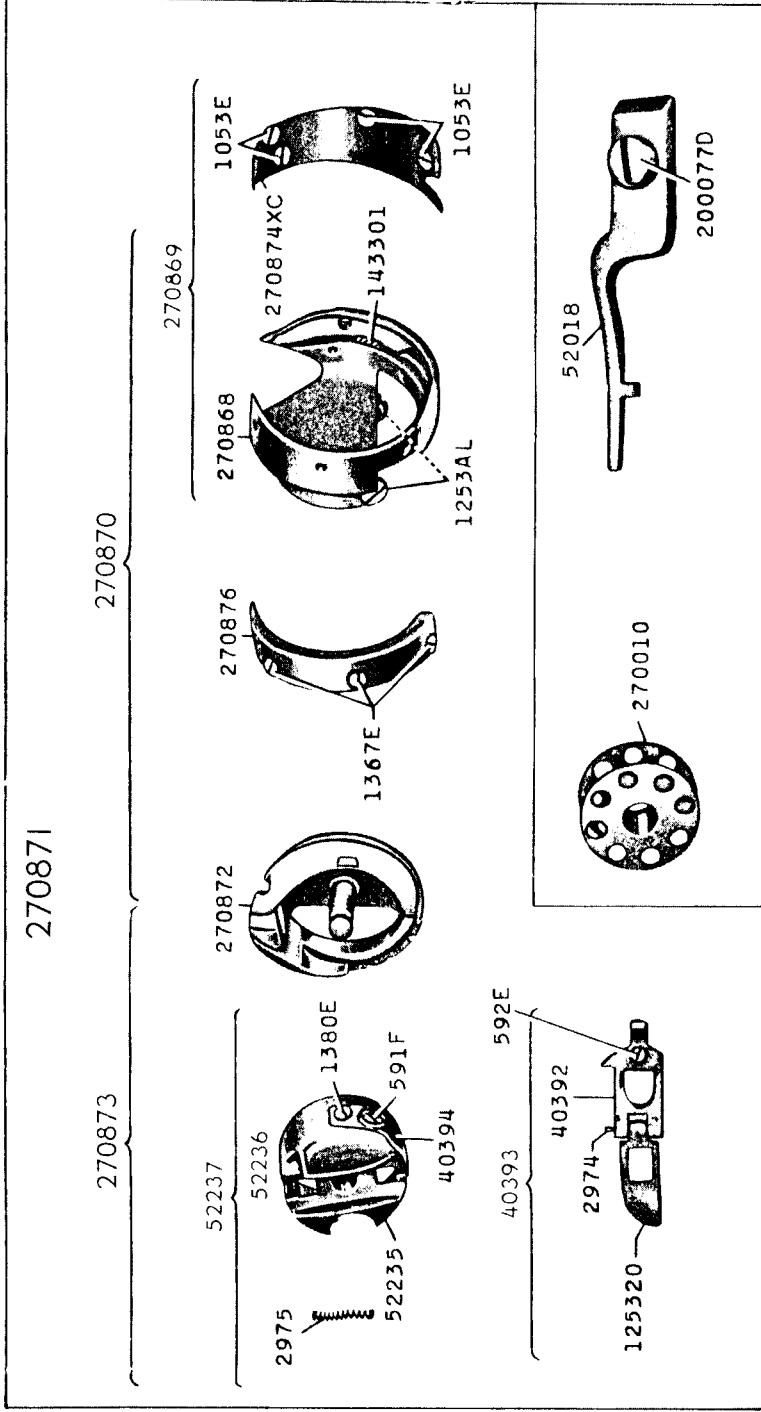

18384 - 3/8

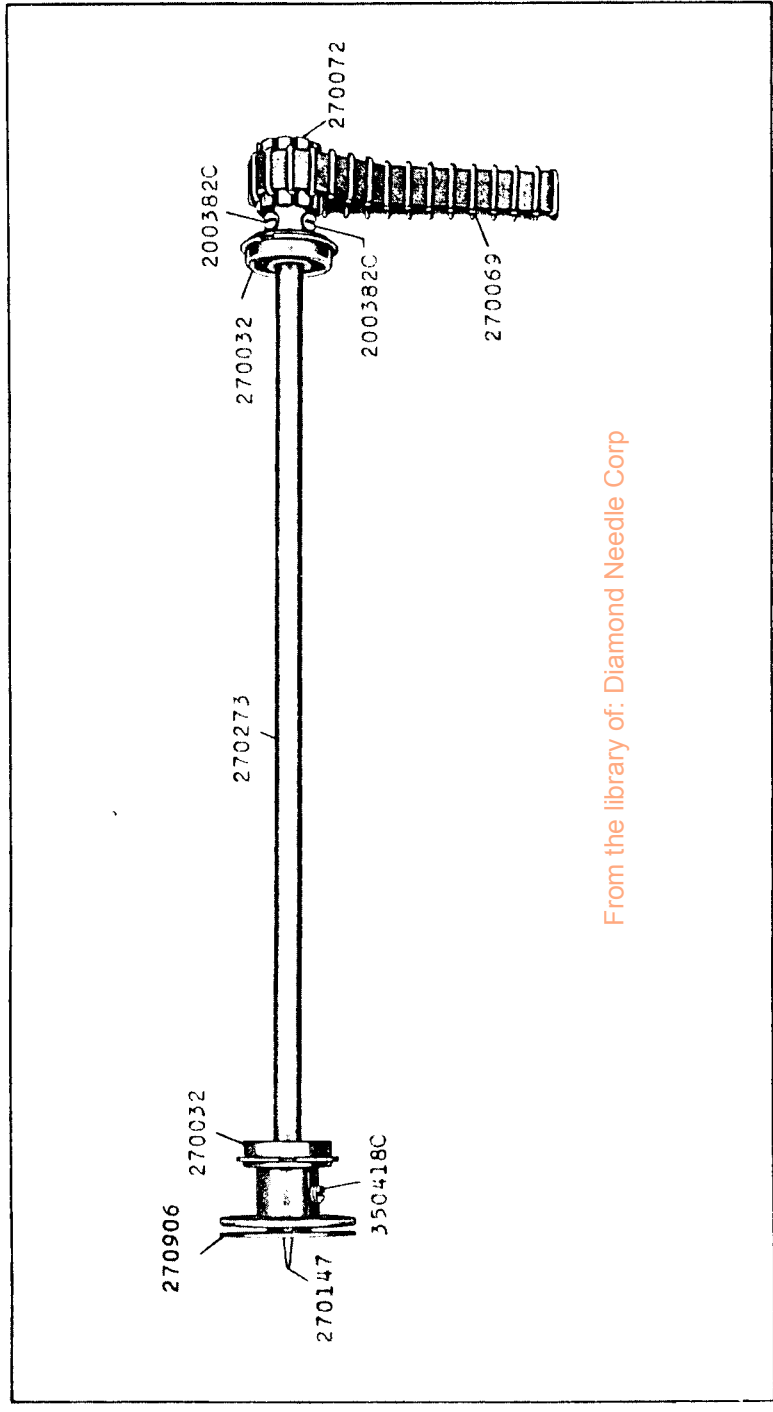

From the library of: Diamond Needle Corp

18389 - 3/8

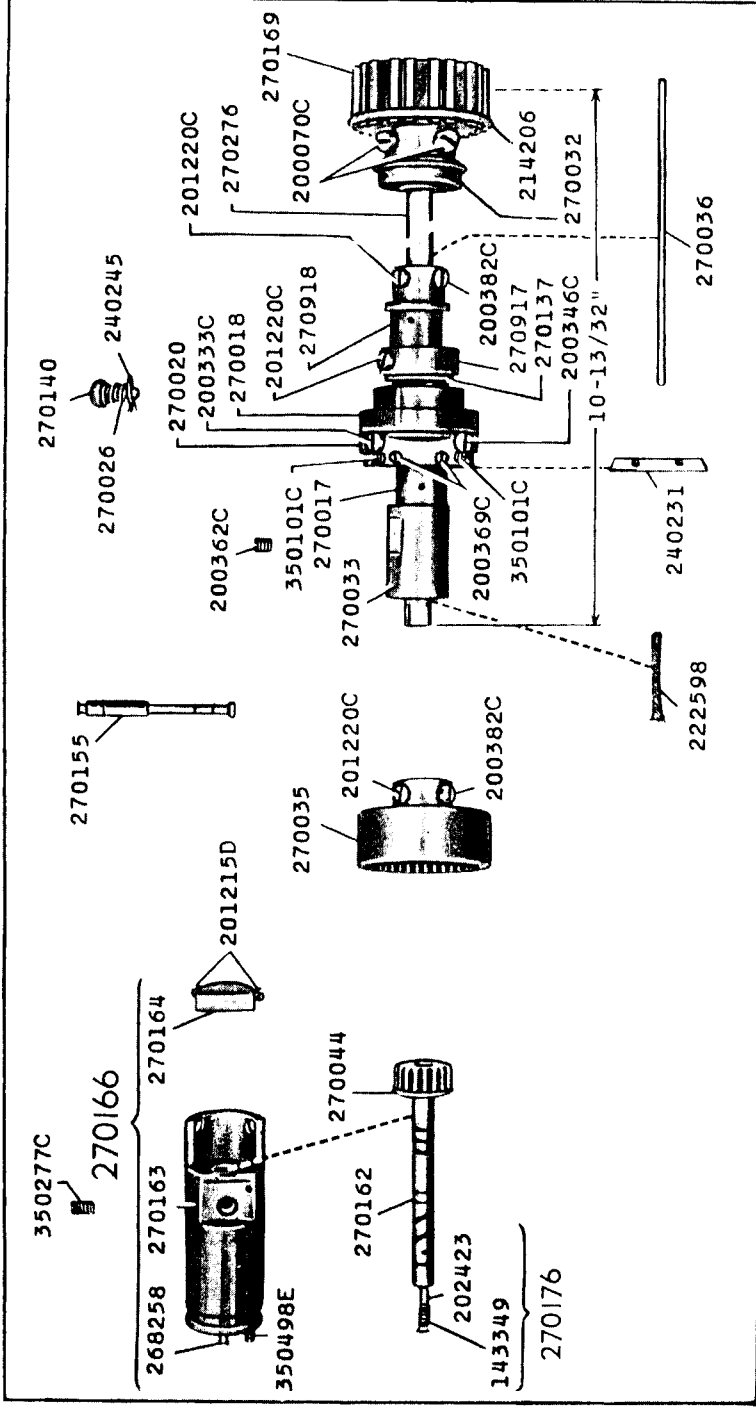

18391 - 3/8

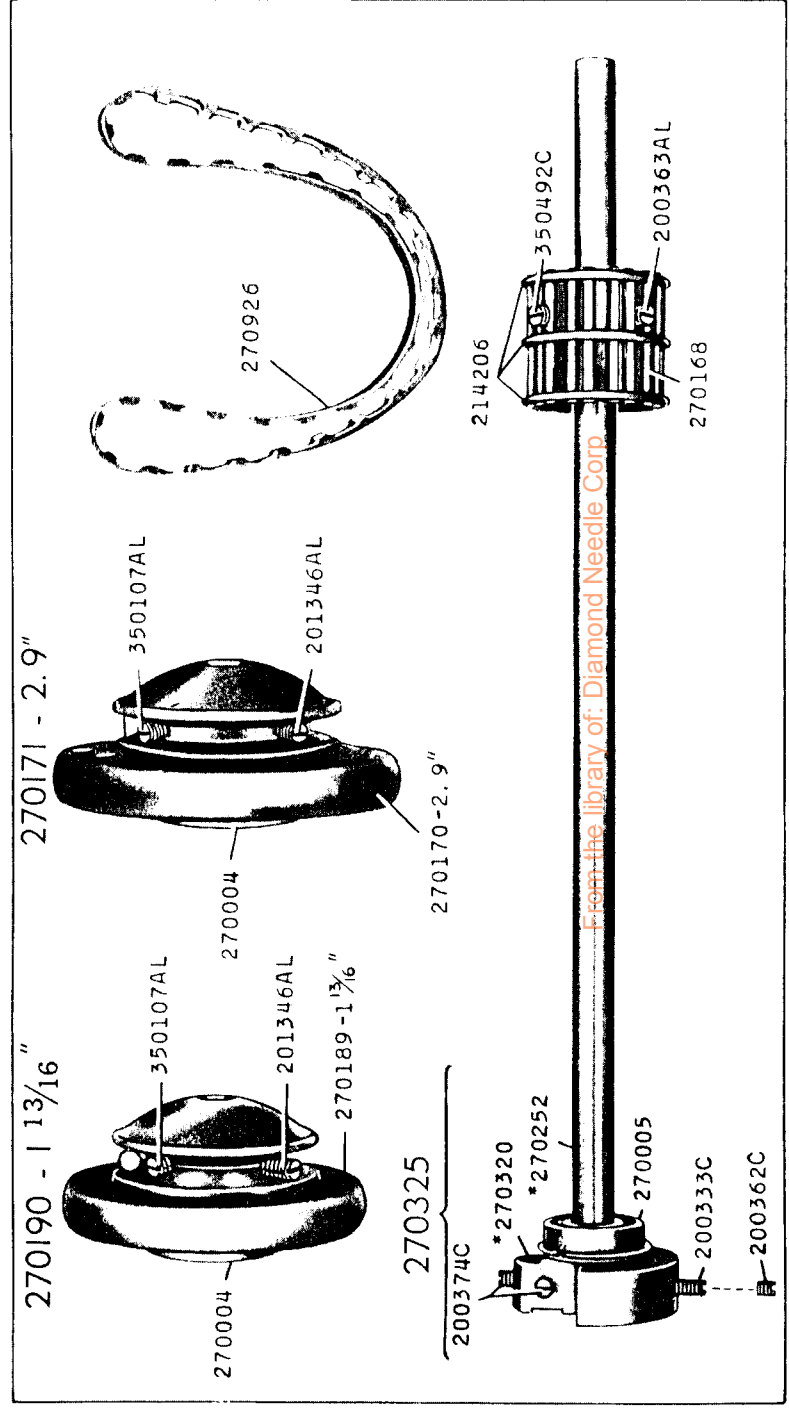

From the library of: Diamond Needle Corp

143365

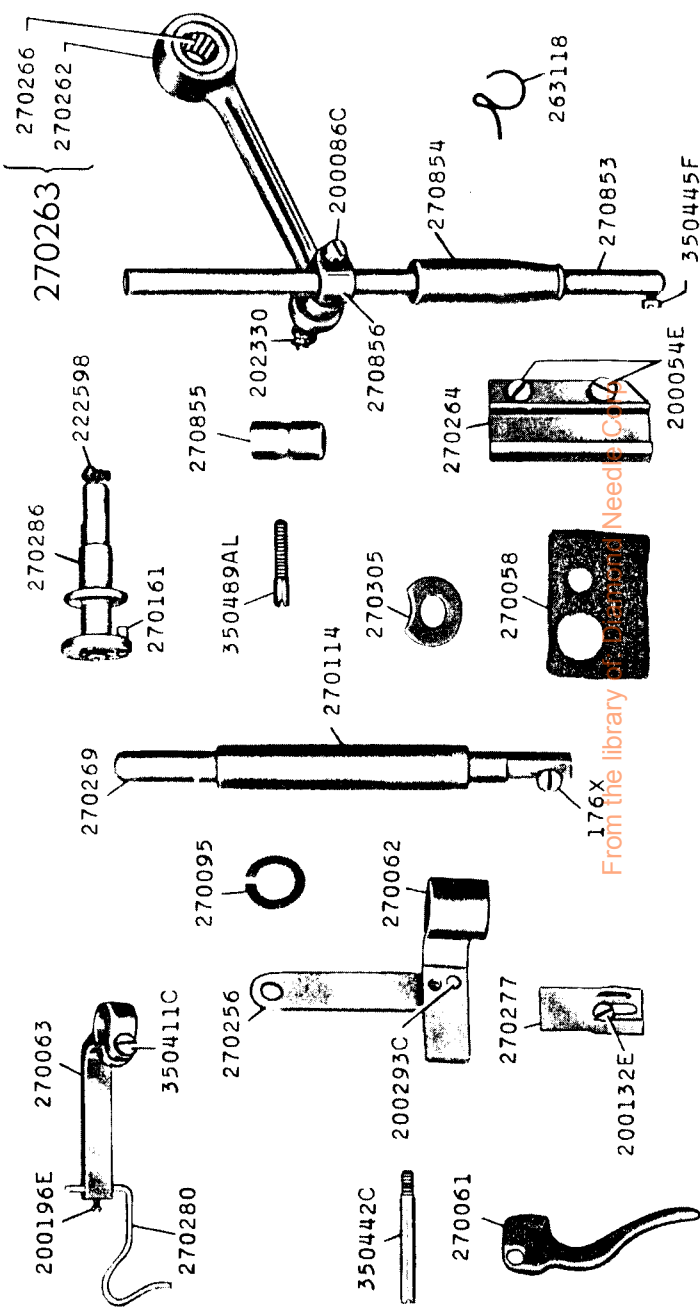
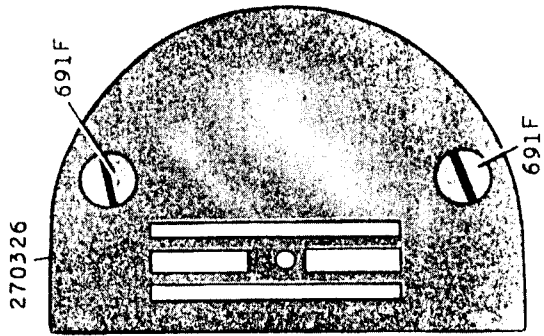
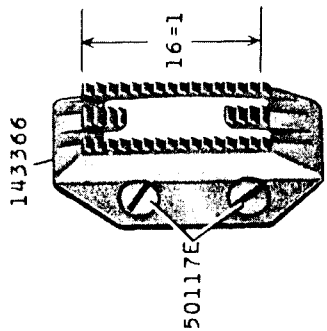
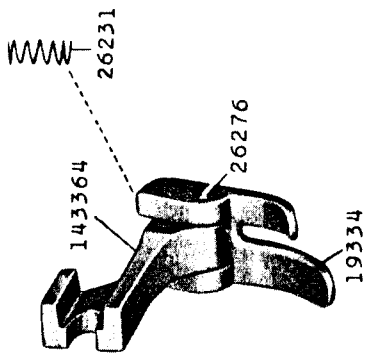

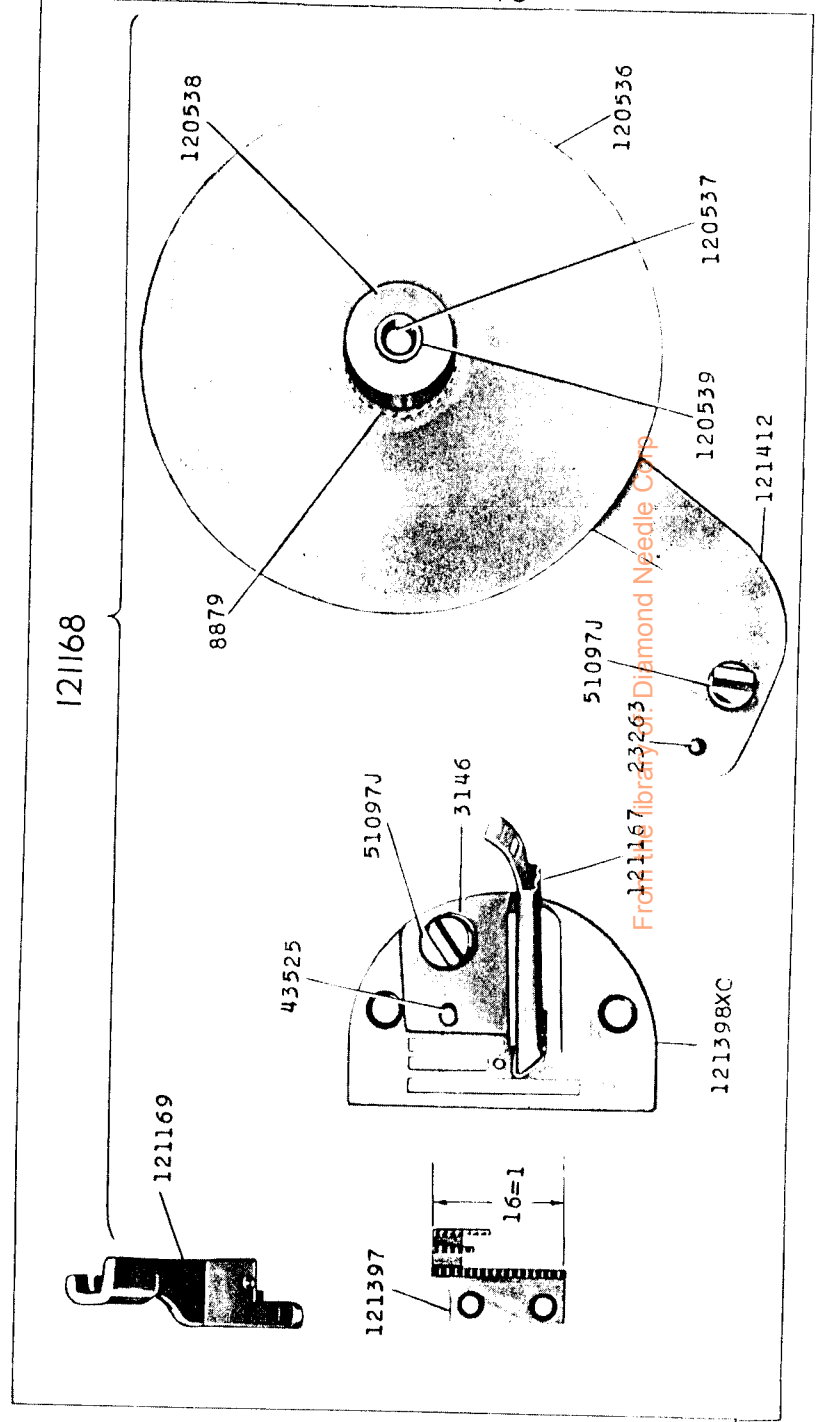
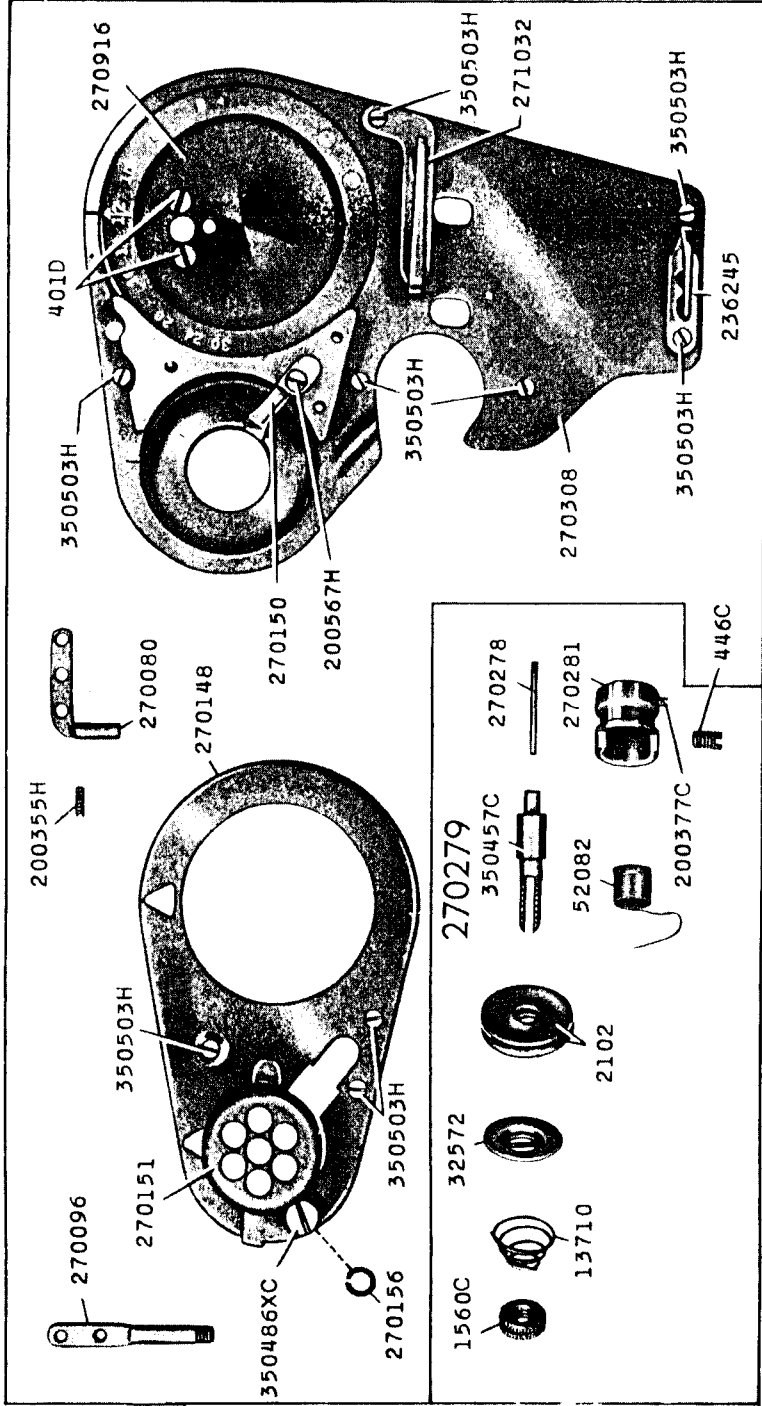

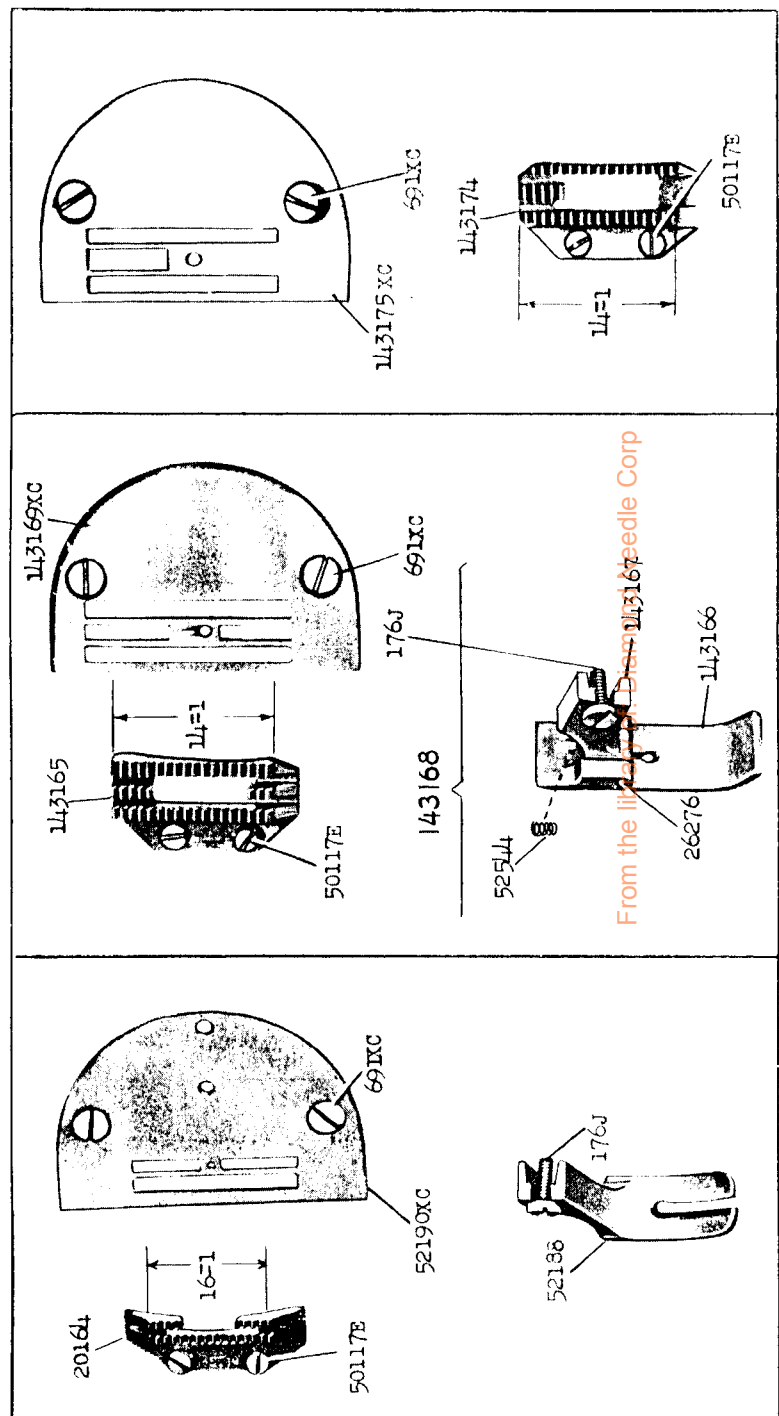
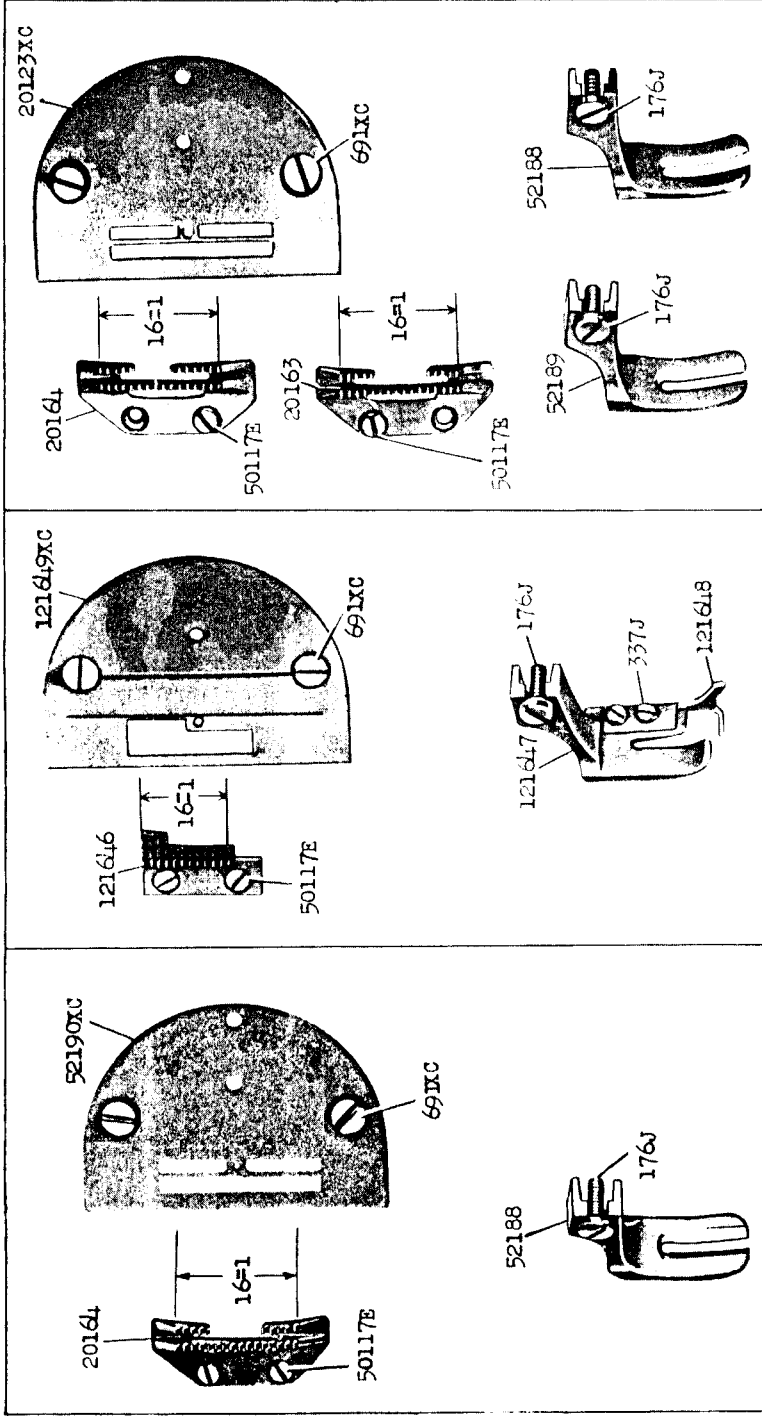

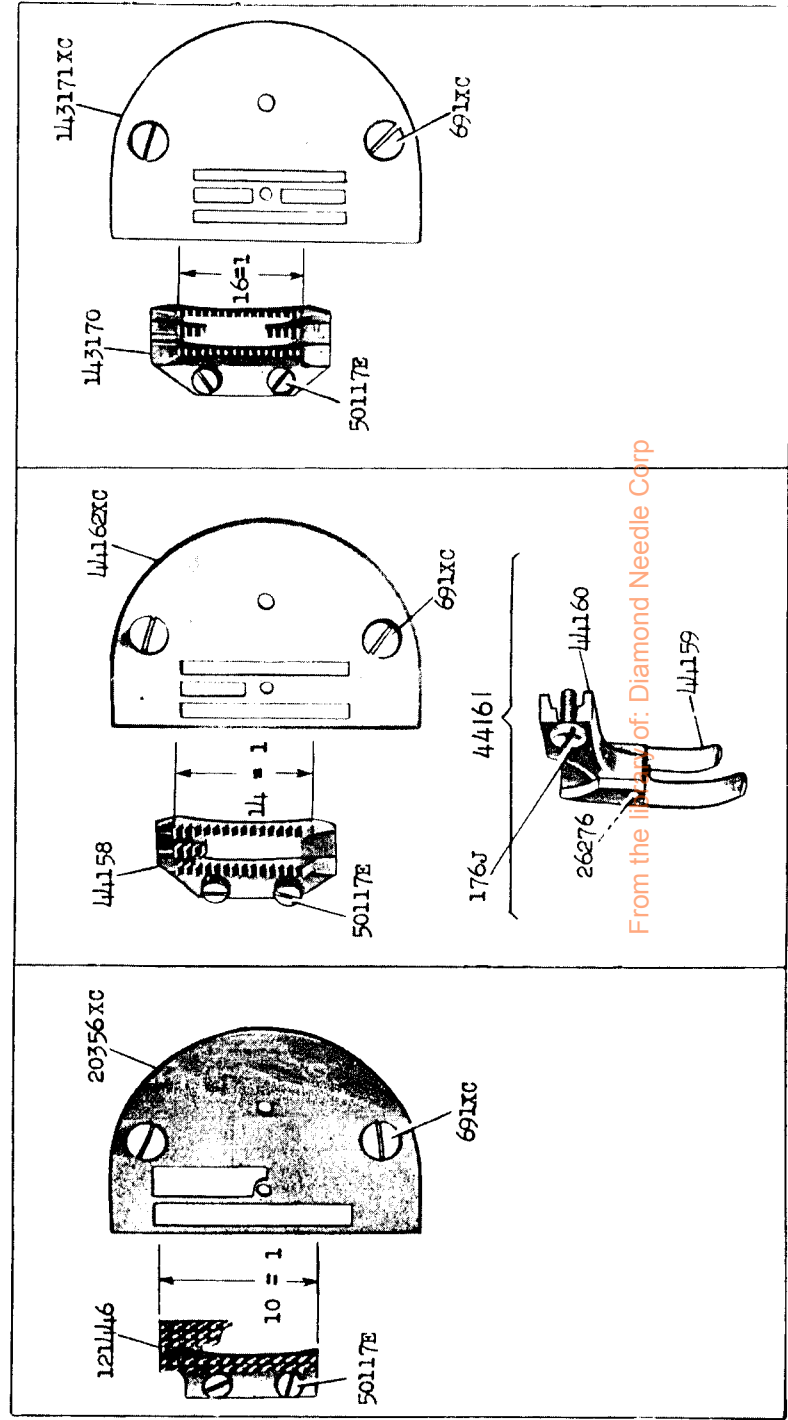
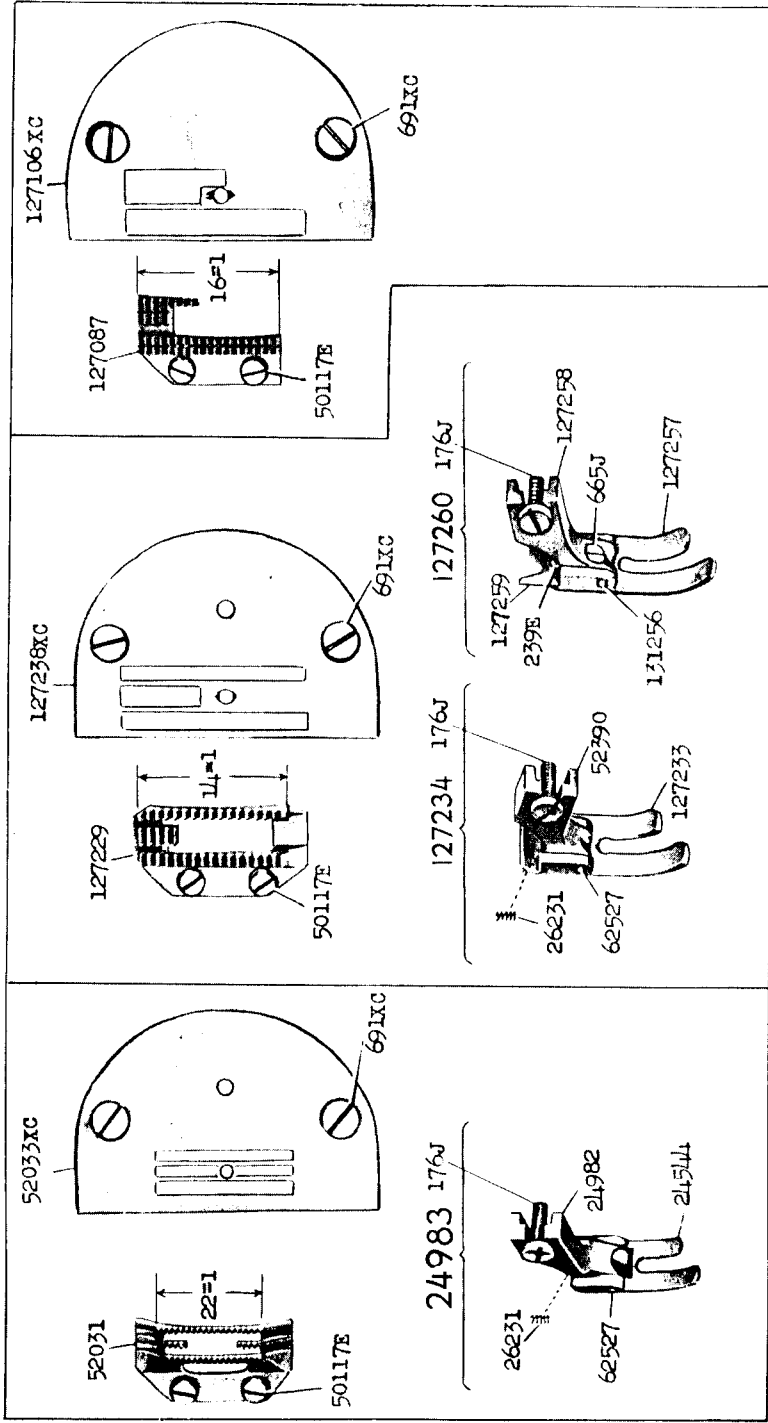

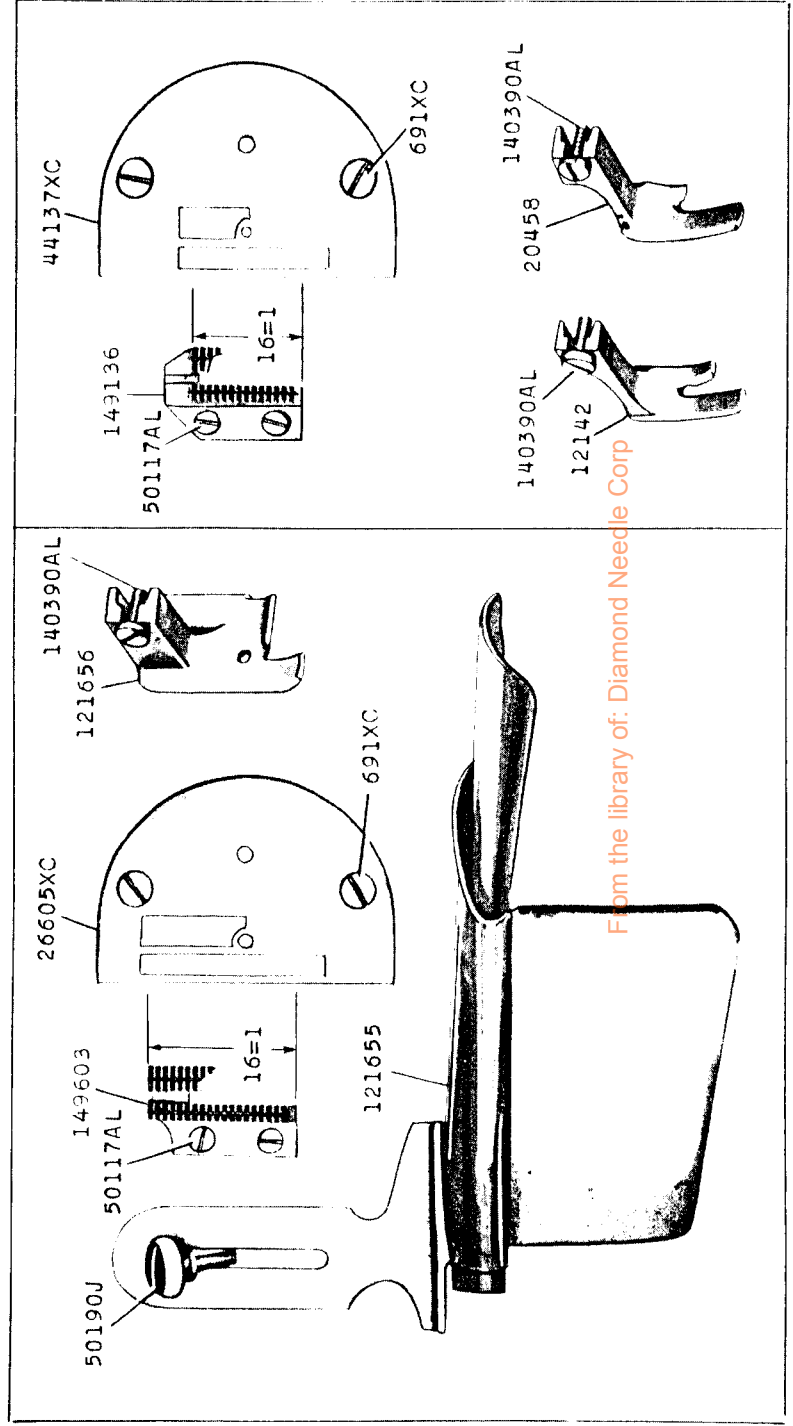
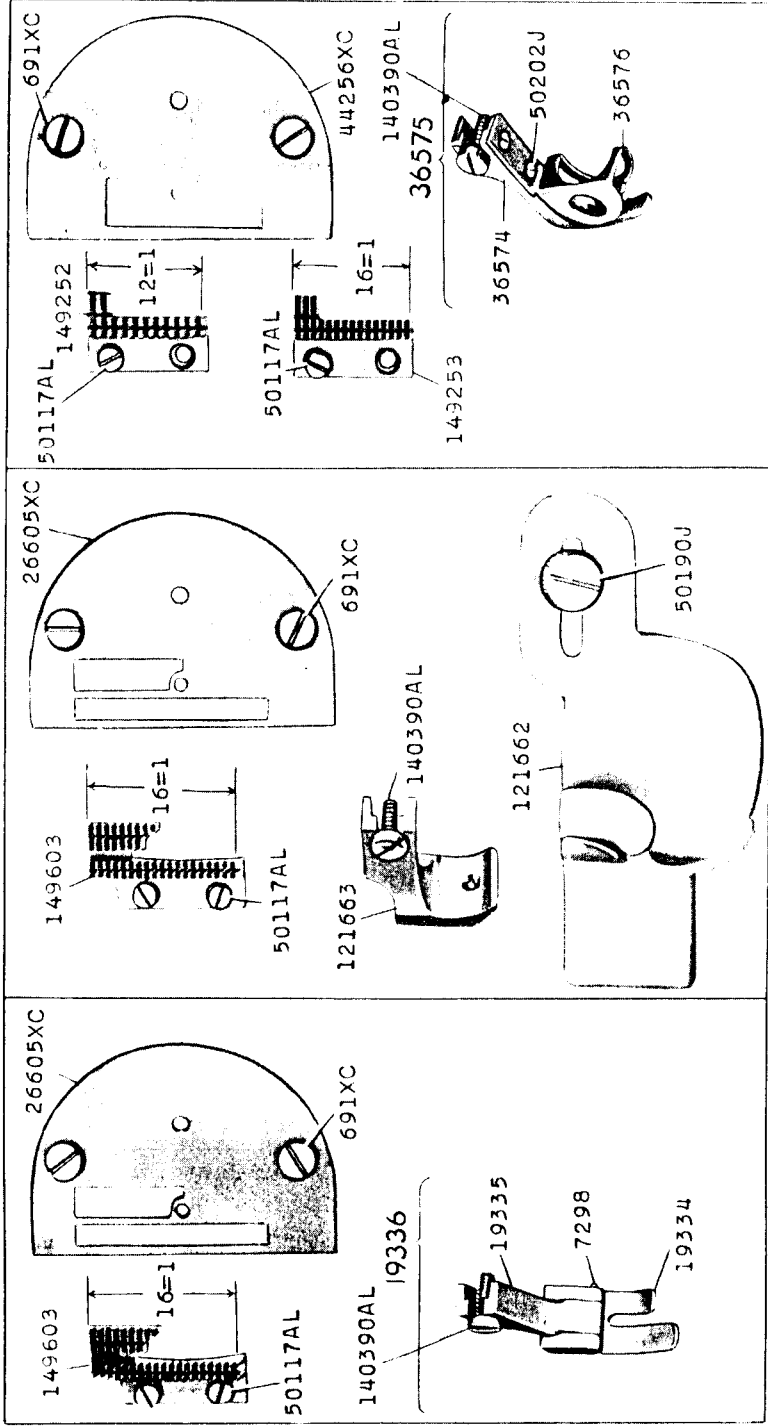

From the library of: Diamond Needle Corp

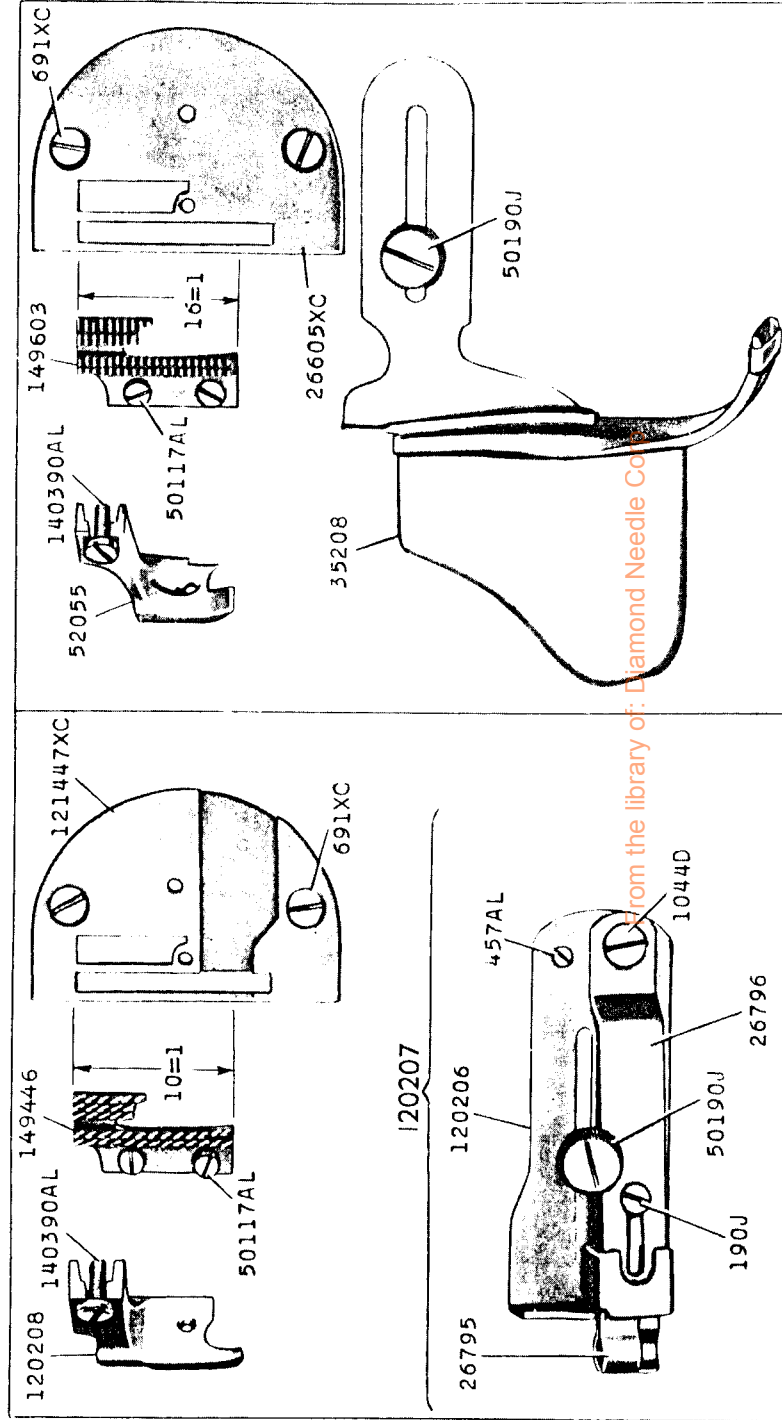
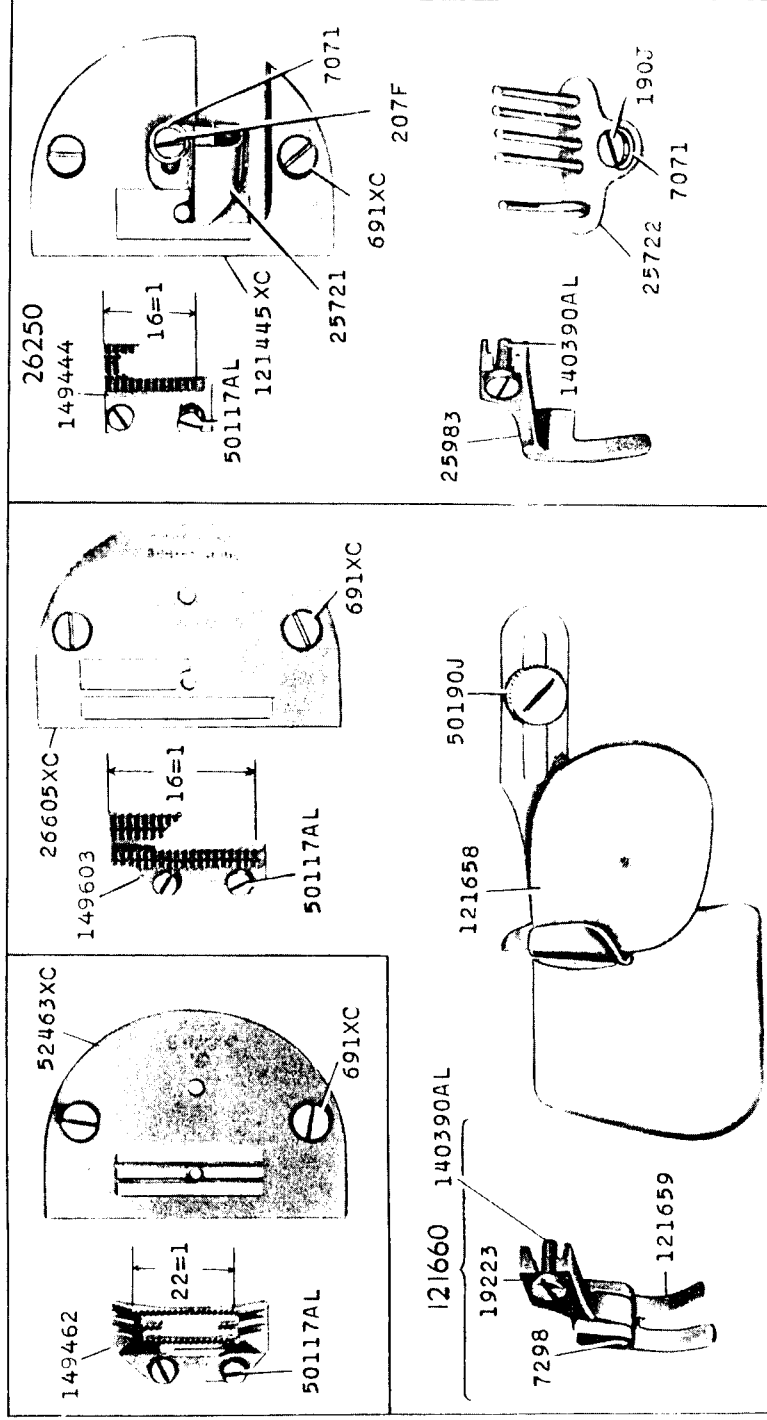

from the library of: Diamond Needle Co.

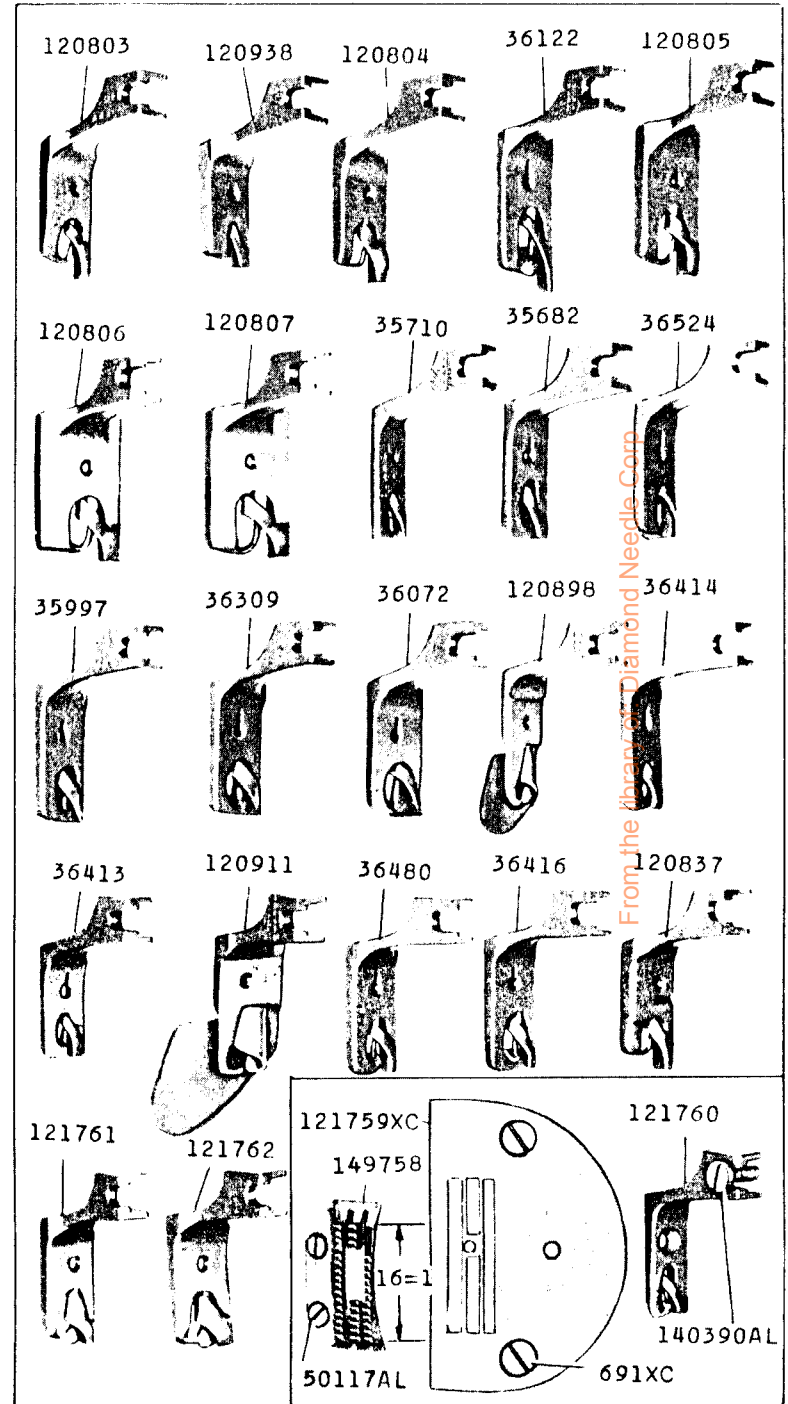
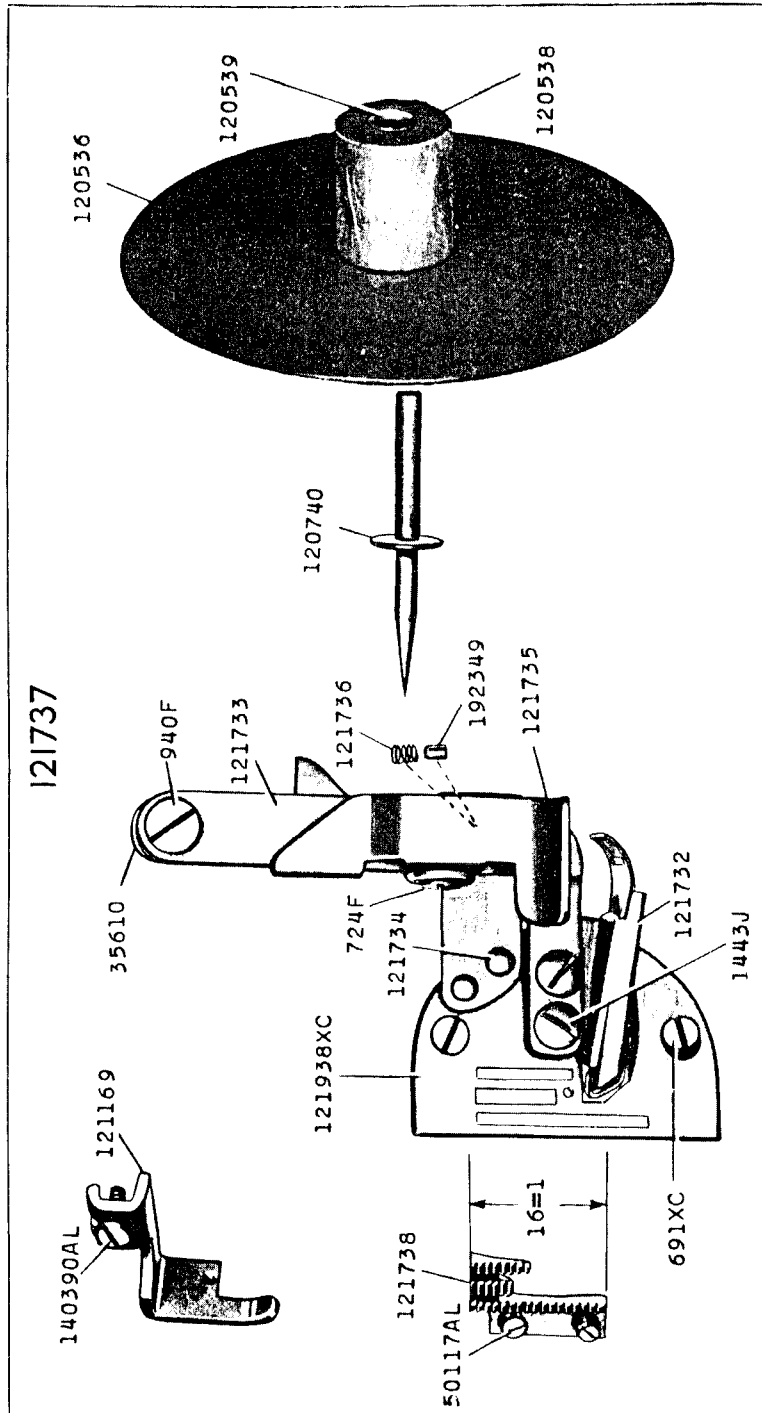

From the Library of Diamond Needle Corp

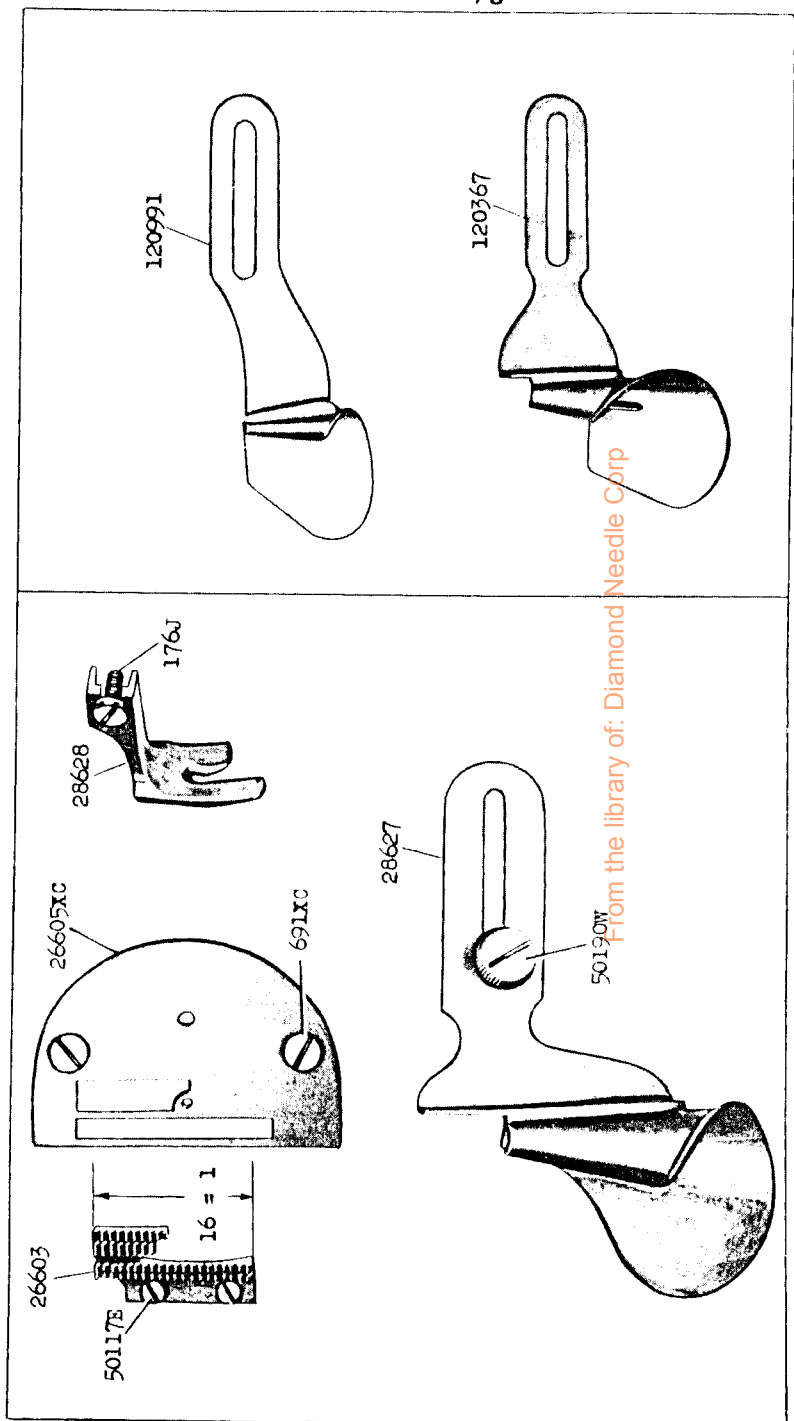
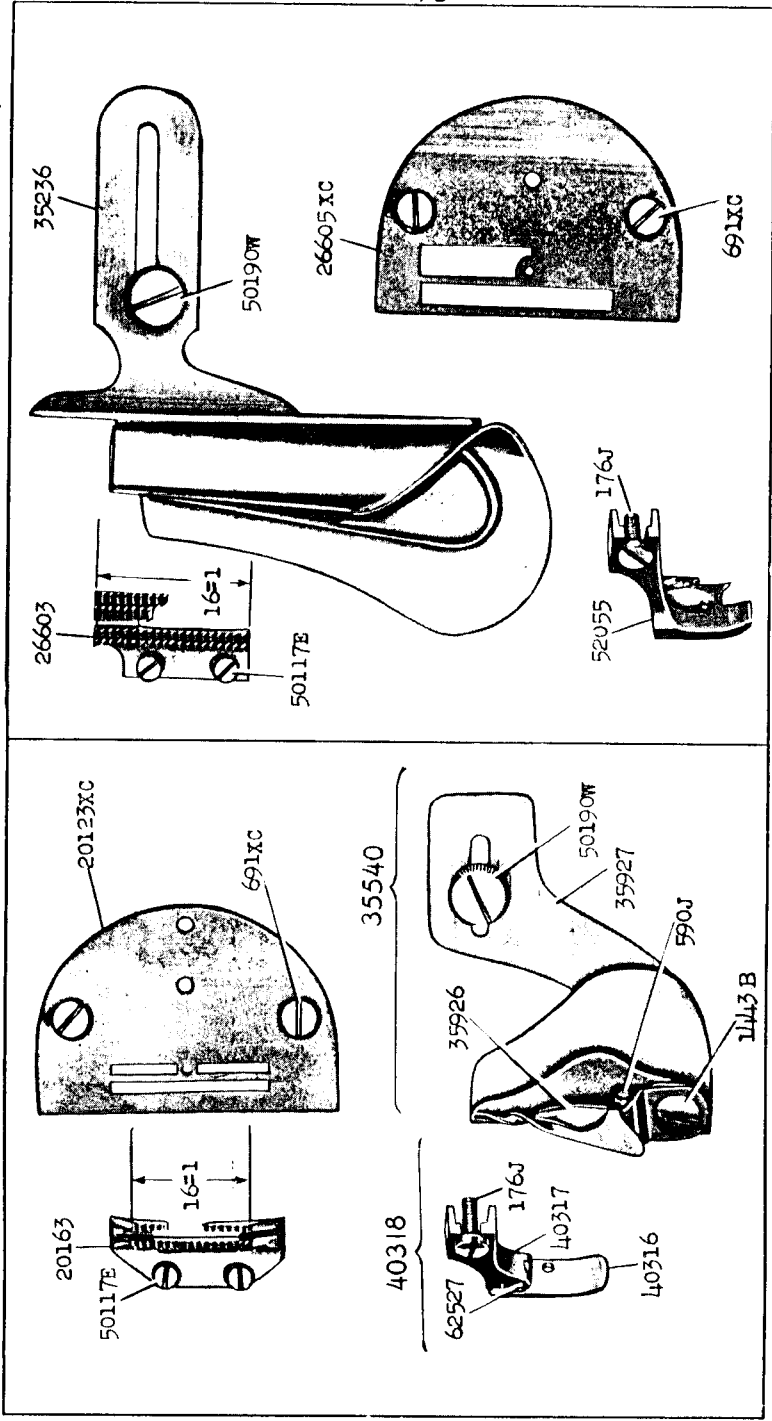

From the library of: Diamond Needle Corp

